

Doppelverzahnung Lizenz Traub  
double tooth system licence Traub

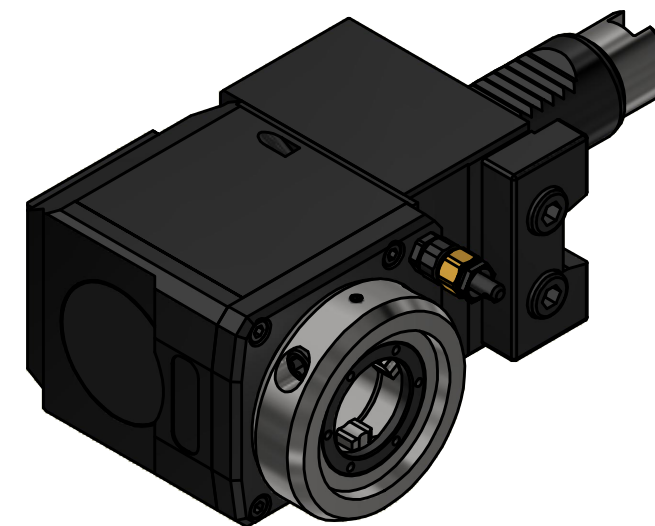

Copyright **EWS Tool Technologies**  
Weitergabe und Vervielfaeltigung dieser Unterlage,  
Verwertung und Mitteilung ihres Inhalts nicht  
gestattet, soweit nicht ausdrecklich zugestanden.  
Zuwiderhandlungen verpflichten zu Schadenersatz.

Bemerkung - Note

Technische Daten - technical data

Benennung - Title

Weight = 4.675 [kg]  
Torque max. (M1/M2) = 24 / 12 [Nm]  
Speed max. (n1/n2) = 6000 / 12000 [1/min]  
Gear ratio (i)=n1:n2 = 1:2

**Radial Bohr und Fräskopf**  
**Radial drilling and milling head**



Nr. - No.  
**60.30VX3G300RL1V#01**

Technische Aenderungen vorbehalten!  
Subject to technical modifications!

IDENT: DEWS259231

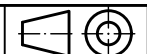

REV: -/A

MNR.

**231556**

