

Spannzange / collet ER25 DIN6499  
Spannbereich / clamping range: 1,0 - 16,0

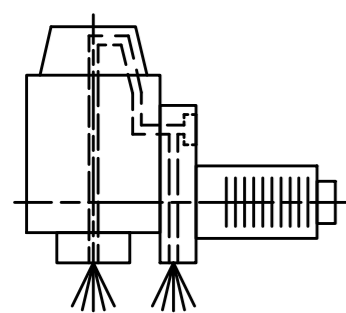

Innen- und Aussenkuehlung / Inside and outside coolant supply  
Kuehlmittelfiltrierung-50µ / coolant filtration-50µ

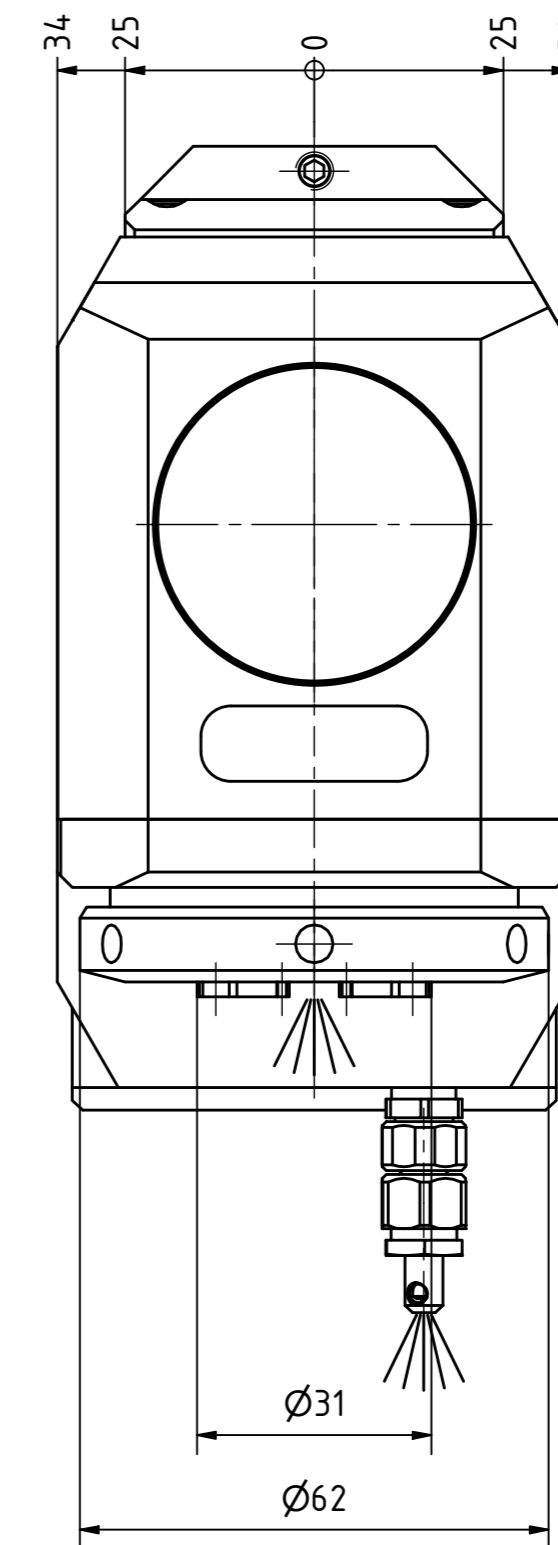
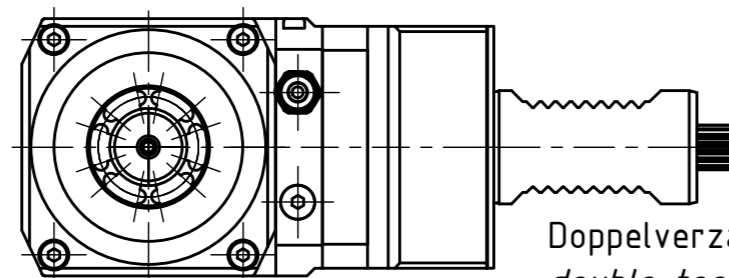

Doppelverzahnung Lizenz Traub  
double tooth system licence Traub

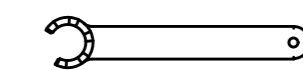
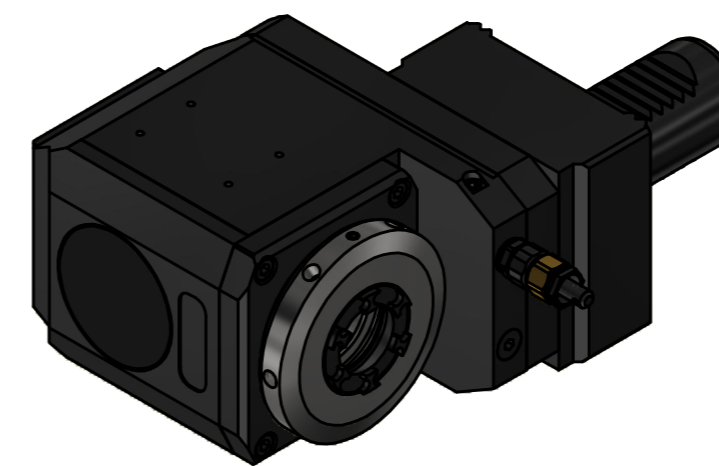

Spannzangenschlüssel für  
innenliegende Mutter  
Clamping wrench for  
internal collet  
225AX

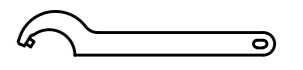

Hakenschlüssel  
mit Zapfen  
Hook wrench  
with fixed pin  
DIN1810 B 58x62

Copyright EWS Tool Technologies  
Weitergabe und Vervielfaeltigung dieser Unterlage,  
Verwertung und Mitteilung ihres Inhalts nicht  
gestattet, soweit nicht ausdrecklich zugestanden.  
Zuwoerhandlungen verpflichten zu Schadenersatz.

Bemerkung - Note  
Für Trockenlauf geeignet!  
Use without coolant fluid allowed!

Technische Daten - technical data  
Weight = 5.013 [kg]  
Torque max. (M1/M2) = 32 / 32 [Nm]  
Speed max. (n1/n2) = 8000 / 8000 [1/min]  
Gear ratio (i)=n1:n2 = 1:1  
Pressure (pmax) = 70 [bar]

Benennung - Title  
Radial Bohr und Fräskopf, zurückges  
Radial drill. and mill. head offset

	<small>EWS Weigela GmbH &amp; Co. KG Maybachstr. 1 D-73066 Uhlingen www.ews-tool.de</small>	<small>Technische Aenderungen vorbehalten! Subject to technical modifications!</small>	
	<small>Nr. - No.</small> 80.3025G300RLIKDWIM#01	<small>IDENT: DEWS258420</small>	

QR