

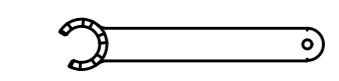

Ceramic Seal

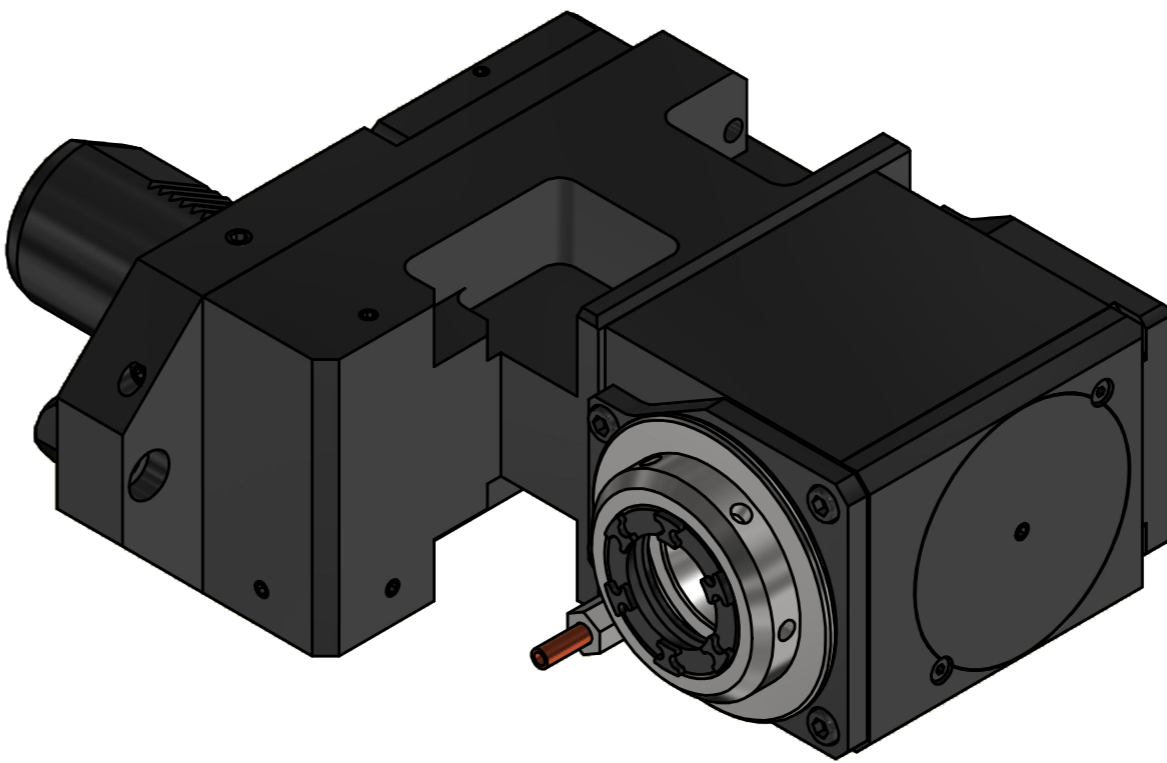

Tech Details

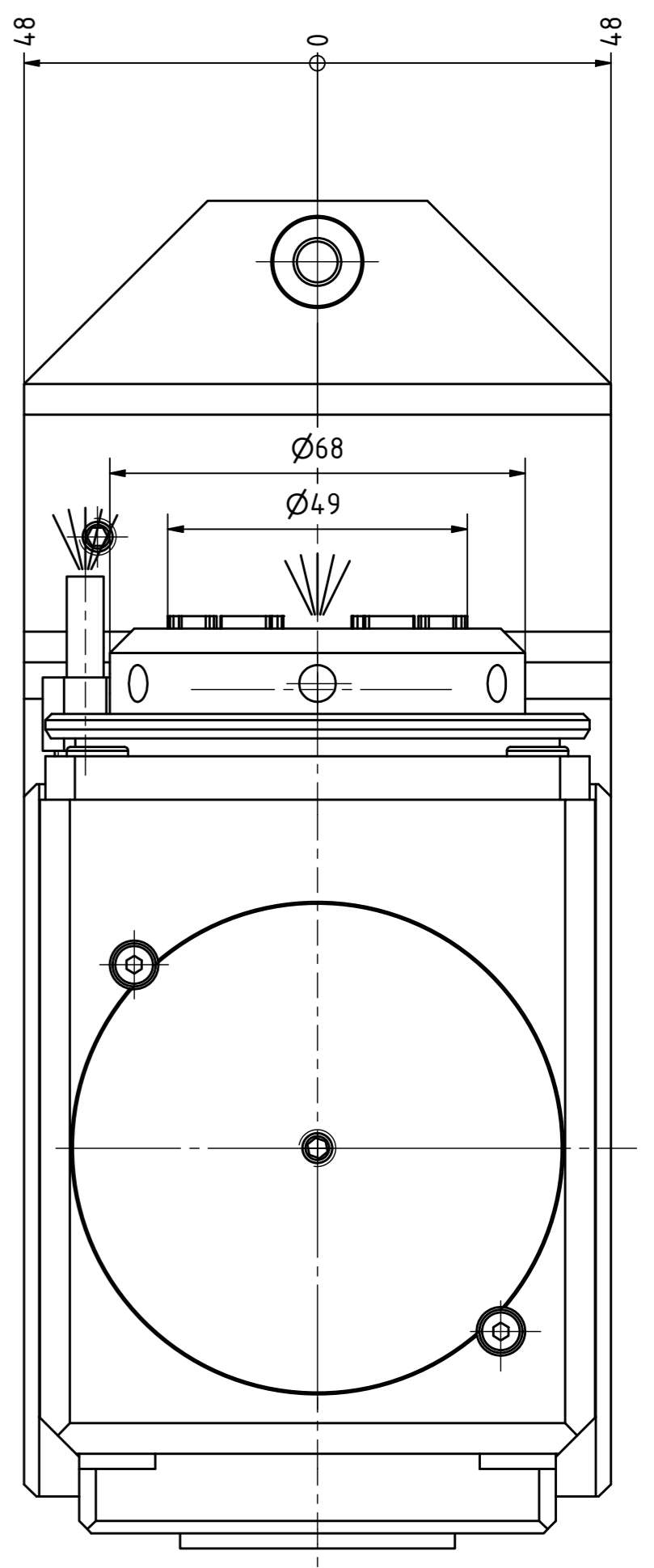
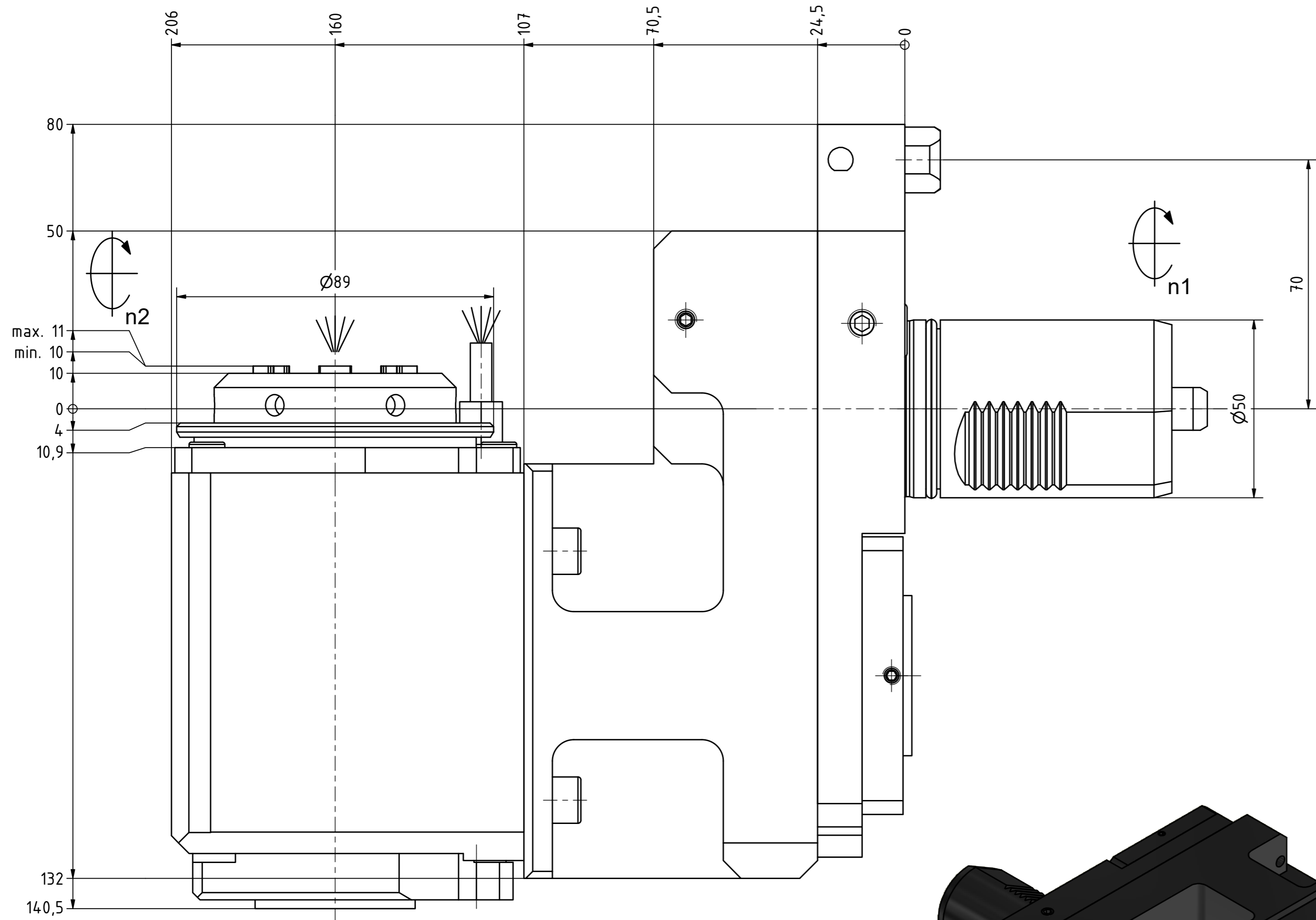

Spannzangenschlüssel für
innenliegende Mutter
Clamping wrench for
internal collet
240AX

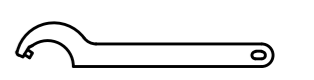

Hakenschlüssel
mit Zapfen
Hook wrench
with fixed pin
DIN1810 B 68x75

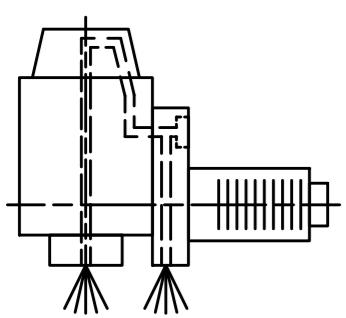

Innen- und Aussenkuehlung / Inside and outside coolant supply
Kuehlmittelfiltrierung=50µ / coolant filtration=50µ

Bemerkung - Note
Für Trockenlauf geeignet!
Use without coolant fluid allowed!

Technische Daten - technical data
Weight = 15 981 [kg]
Torque max. (M1/M2) = 100 / 100 [Nm]
Speed max. (n1/n2) = 4 000 / 4 000 [1/min]
Gear ratio (i)=n1:n2 = 1:1
Pressure (pmax) = 70 [bar]

Benennung - Title
Radial Bohr und Fräskopf, zurückges
Radial drill. and mill. head offset

EWS Tool Technologies
EWS Weigle GmbH & Co. KG
Maybachstr. 1
D-73066 Uhlingen
www.ews-tool.de
Nr. - No.
80.5040SQT28LIKDIM

Technische Änderungen vorbehalten!
Subject to technical modifications!
IDENT: DEWS258046
REV: -/B
MNR.
231222



Copyright **EWS Tool Technologies**
Weitergabe und Vervielfältigung dieser Unterlage,
Verwertung und Mitteilung ihres Inhalts nicht
gestattet, soweit nicht ausdrücklich zugestanden.
Zuwendungen verpflichten zu Schadenersatz.