

Spannzange / collet ER40 DIN6499  
 Spannbereich / clamping range: 3,0 - 26,0

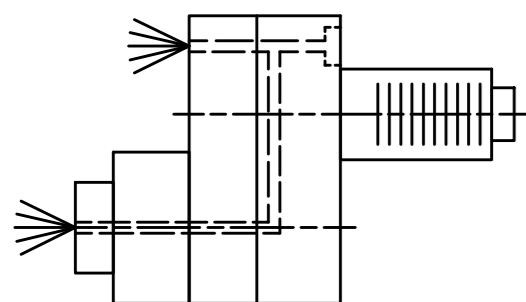
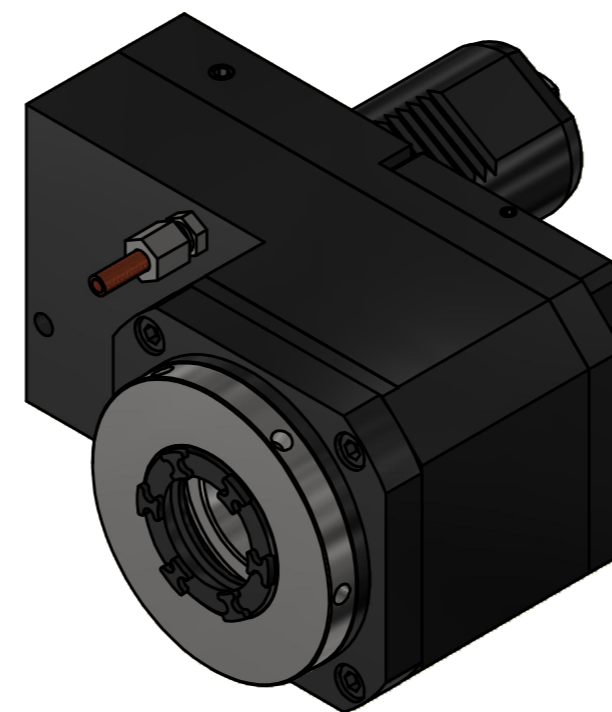
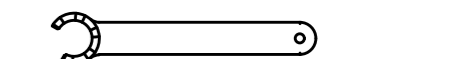

Innen- und Aussenkuehlung  
 Inside and outside coolant supply

  
 Hakenschlüssel  
 mit Zapfen  
 Hook wrench  
 with fixed pin  
 DIN1810 B 80x90

  
 Spannzangenschlüssel für  
 innenliegende Mutter  
 Clamping wrench for  
 internal collet  
 240AX

Copyright **EWS Tool Technologies**  
 Weitergabe und Vervielfältigung dieser Unterlage,  
 Verwertung und Mitteilung ihres Inhalts nicht  
 gestattet, soweit nicht ausdrücklich zugestanden.  
 Zuwiderhandlungen verpflichten zu Schadenersatz.

Bemerkung - Note  
 Nicht ohne Kuehlmittel betreiben!  
 Not for use without coolant-fluid!

Technische Daten - technical data  
 Weight = 10.903 [kg]  
 Torque max. (M1/M2) = [Nm]  
 Speed max. (n1/n2) = [1/min]  
 Gear ratio (i)=n1:n2 =  
 Pressure (pmax) = [bar]

Benennung - Title  
**Axial Bohr u. Fräskopf achsversetzt**  
**Ax. drill. and mill. head offset**

**EWS** Tool Technologies  
 EWS Weigle GmbH & Co. KG  
 Maybachstr. 1  
 D-73066 Uhlingen  
 www.ews-tool.de  
 Nr. - No.  
**50.5040KRSQT28RIKIM**

Technische Aenderungen vorbehalten!  
 Subject to technical modifications!  
 IDENT: DEWS257373

REV: -/A  
 MNR.  
**231220**

