

EWS.Varia

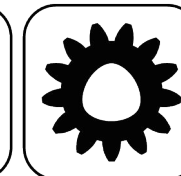

Butterfly Seal



Polygon Joint

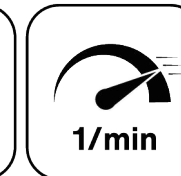

Highspeed
1/min

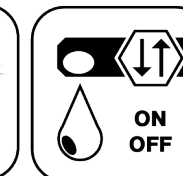

Coolant Management
ON OFF



Tech Details

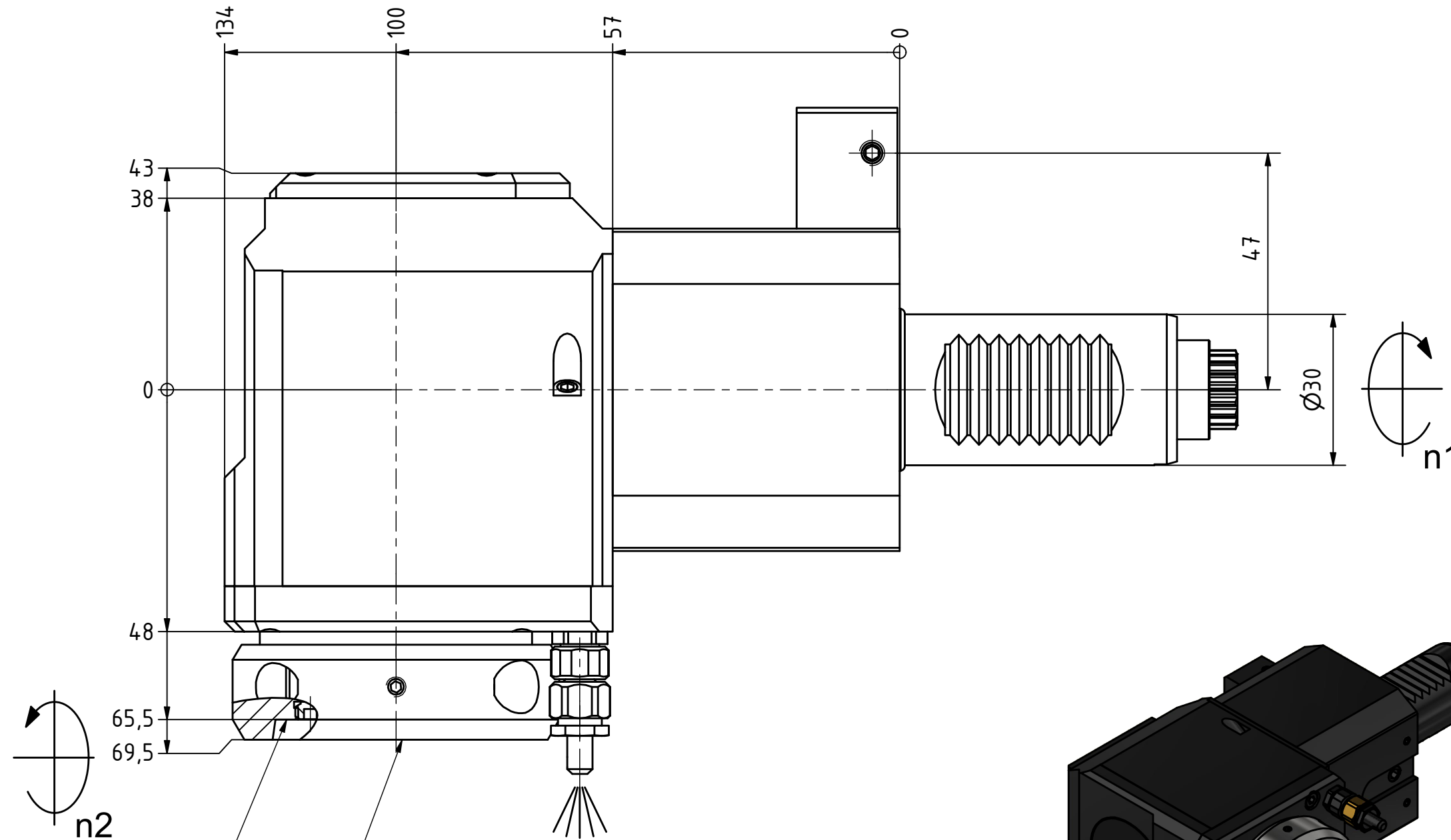

Anlagefläche
contact surface

EWS-Varia VX3

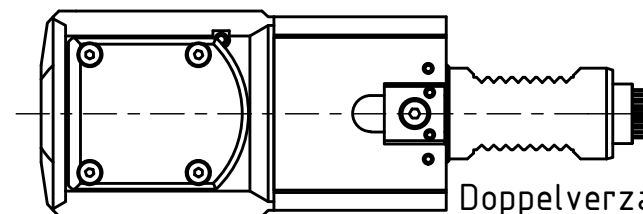

Doppelverzahnung Lizenz Traub
double tooth system licence Traub

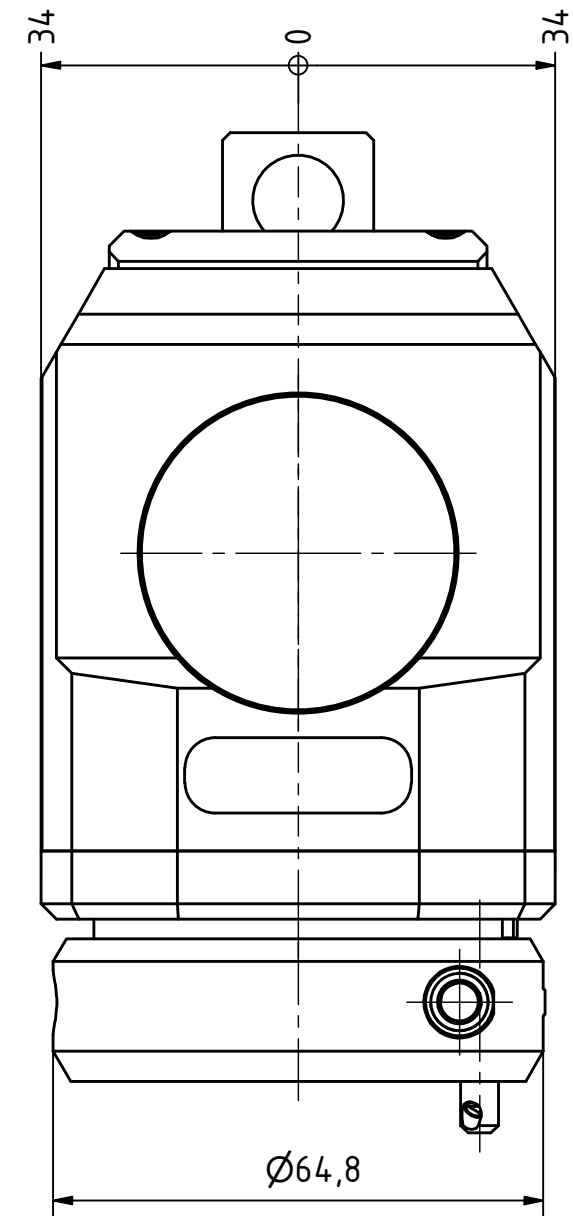
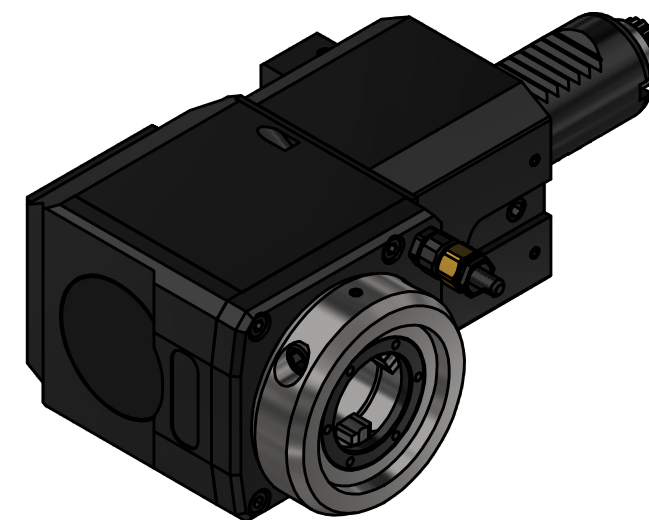

Copyright **EWS Tool Technologies**
Weitergabe und Vervielfaeltigung dieser Unterlage,
Verwertung und Mitteilung ihres Inhalts nicht
gestattet, soweit nicht ausdrecklich zugestanden.
Zuwiderhandlungen verpflichten zu Schadenersatz.

Bemerkung - Note

Technische Daten - technical data

Weight = 4.746 [kg]
Torque max. (M1/M2) = 24 / 12 [Nm]
Speed max. (n1/n2) = 6000 / 12000 [1/min]
Gear ratio (i)=n1:n2 = 1:2

Benennung - Title

Radial Bohr und Fräskopf
Radial drilling and milling head

EWS
Tool Technologies
EWS Weigele GmbH & Co. KG
Maybachstr. 1
D-73066 UHINGEN
www.ews-tools.de

Technische Aenderungen vorbehalten!
Subject to technical modifications!

IDENT: DEWS256957

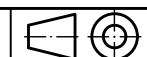

REV: -/A

Nr. - No.

60.30VX3LCTXRL1#01

MNR.

231119

QR