

max. 65,5
min. 62

SW30

Spannzange / collet ER20 DIN6499
Spannbereich / clamping range: 1,0 - 13,0

Gewindebohrzange / tapping collet
ET-1-20 M2-M6

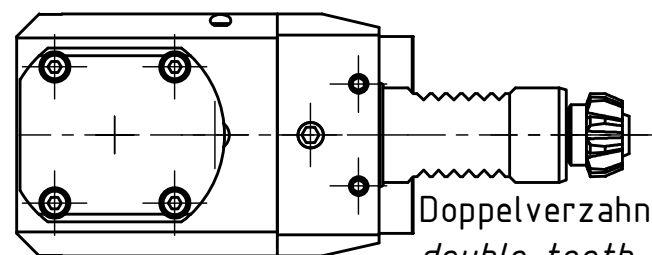
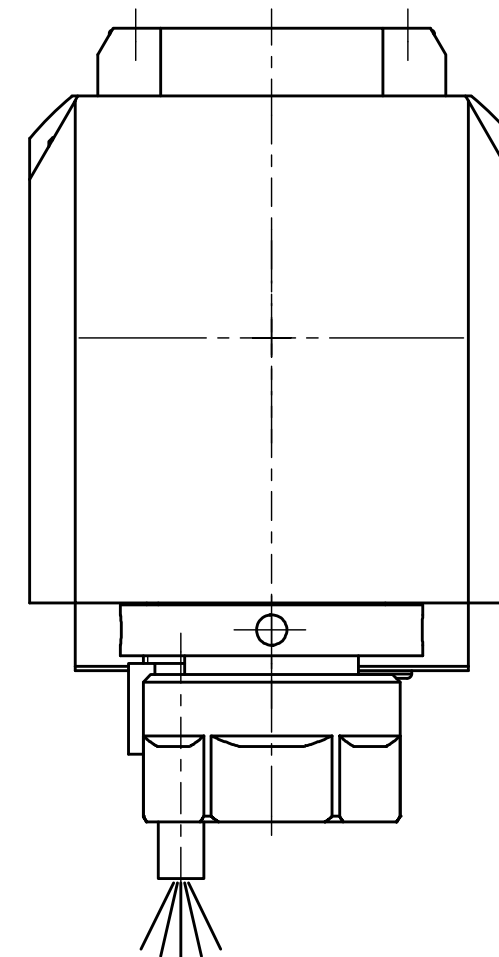
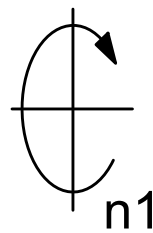
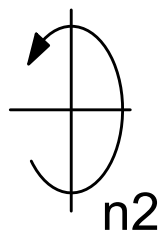

Doppelverzahnung Lizenz Traub
double tooth system licence Traub

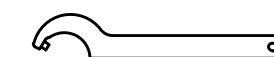
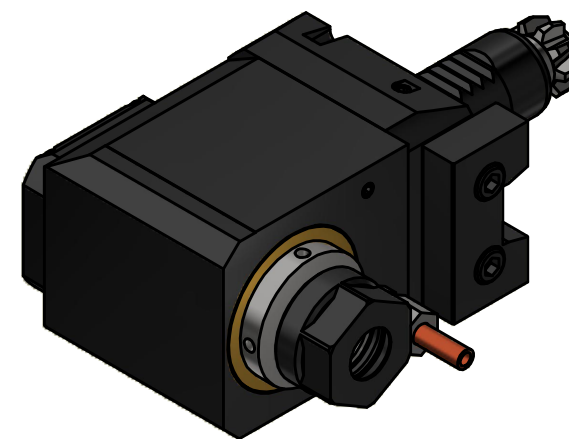

Hakenschlüssel
mit Zapfen
Hook wrench
with fixed pin
DIN1810 B 40x42

Copyright **EWS Tool Technologies**
Weitergabe und Vervielfältigung dieser Unterlage,
Verwertung und Mitteilung ihres Inhalts nicht
gestattet, soweit nicht ausdrücklich zugestanden.
Zu widerhandlungen verpflichten zu Schadenersatz.

Bemerkung - Note

Technische Daten - technical data

Weight = 3.126 [kg]
Torque max. (M1/M2) = 25 / 25 [Nm]
Speed max. (n1/n2) = 8000 / 8000 [1/min]
Gear ratio (i)=n1:n2 = 1:1

Benennung - Title

Radial Bohr und Fräskopf
Radial drilling and milling head

EWS
Tool Technologies

EWS Weigele GmbH & Co. KG
Maybachstr. 1
D-73066 UHINGEN
www.ews-tools.de

Technische Änderungen vorbehalten!
Subject to technical modifications!

IDENT: DEWS265576



REV: -/A

Nr. - No.

60.2520ABCRLV

MNR.

230975

QR