

Hakenschlüssel mit Zapfen
Hook wrench with fixed pin
DIN1810 B 58x62

Spannzangenschlüssel für innenliegende Mutter
Clamping wrench for internal collet
225AX

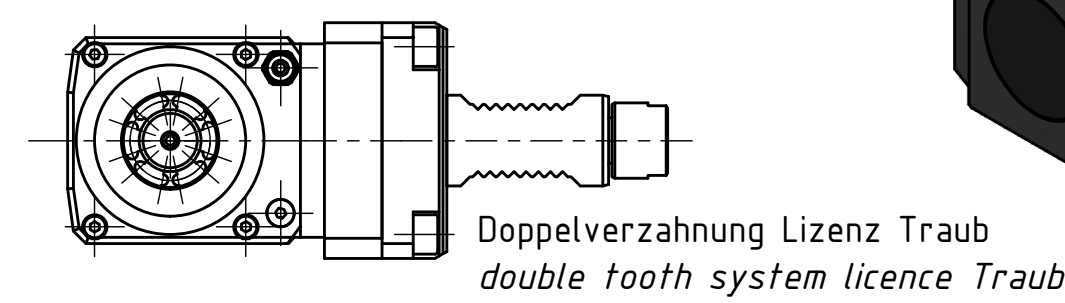
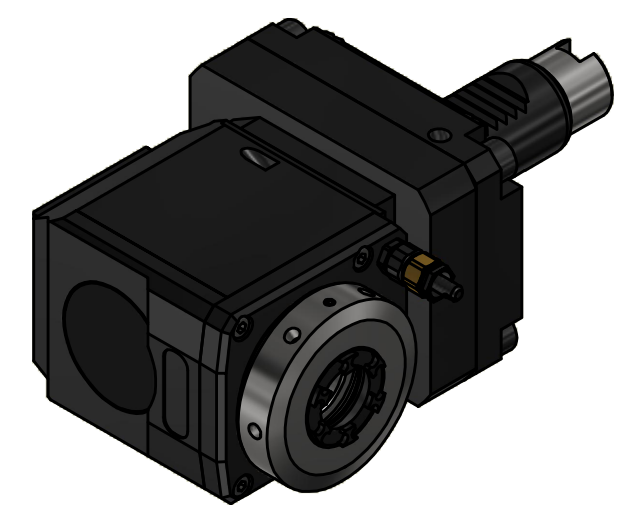

Copyright **EWS Tool Technologies**
Weitergabe und Vervielfaeltigung dieser Unterlage, Verwertung und Mitteilung ihres Inhalts nicht gestattet, soweit nicht ausdrecklich zugestanden. Zuwiderhandlungen verpflichten zu Schadenersatz.

Bemerkung - Note

Technische Daten - technical data

Weight	= 5.556 [kg]
Torque max. (M1/M2)	= 24 / 12 [Nm]
Speed max. (n1/n2)	= 6000 / 12000 [1/min]
Gear ratio (i)=n1:n2	= 1:2

Benennung - Title

	EWS Weigle GmbH & Co. KG Maybachstr. 1 D-73066 Uthingen www.ews-tools.de	Technische Aenderungen vorbehalten! Subject to technical modifications! IDENT: DEWS264137	
	Nr. - No. 60.3025G300RL1WIM	MNR. 230820	REV: -/A