

1/min Coolant Management Tech Details

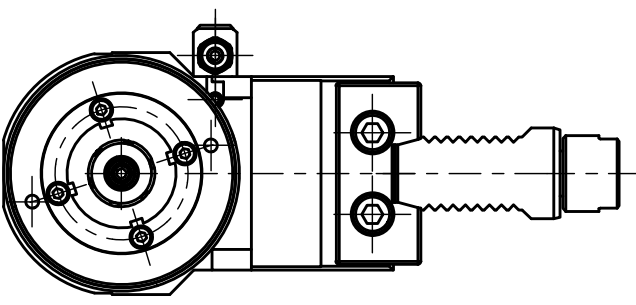

Doppelverzahnung Lizenz Traub
double tooth system licence Traub

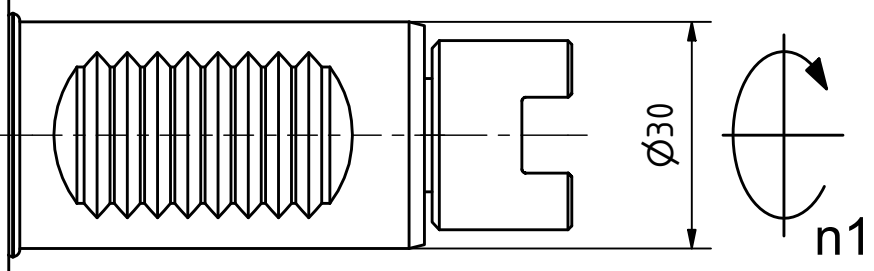

Ø30
n1

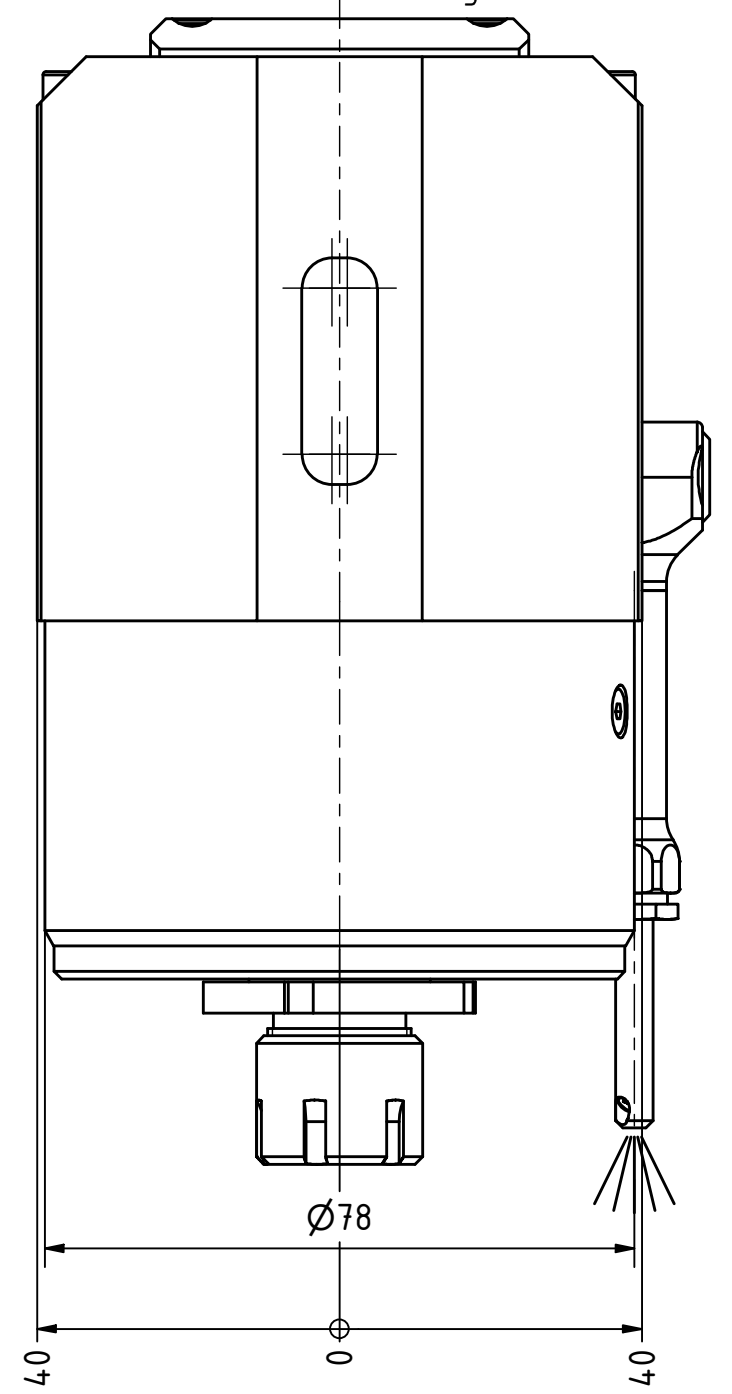

Ø78
40

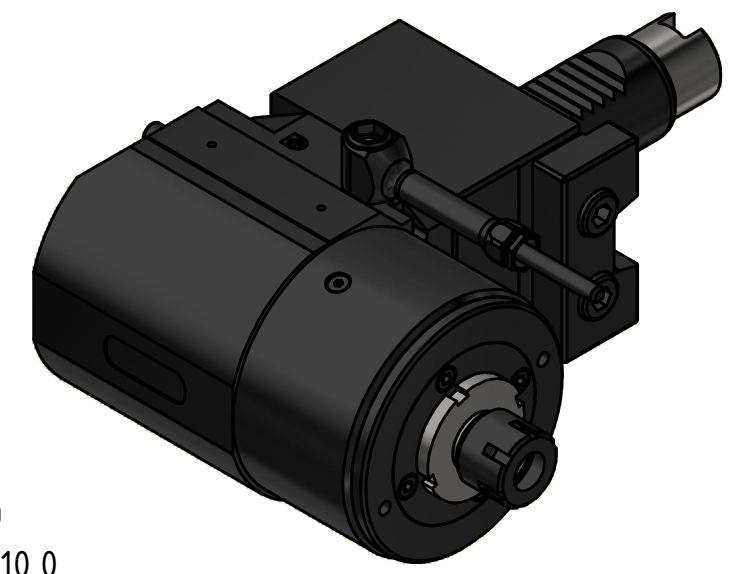

Hakenschlüssel mit Nase
Hook wrench with nose end
DIN1810 A 36x38

Spannzangenschlüssel
Clamping wrench
216 M

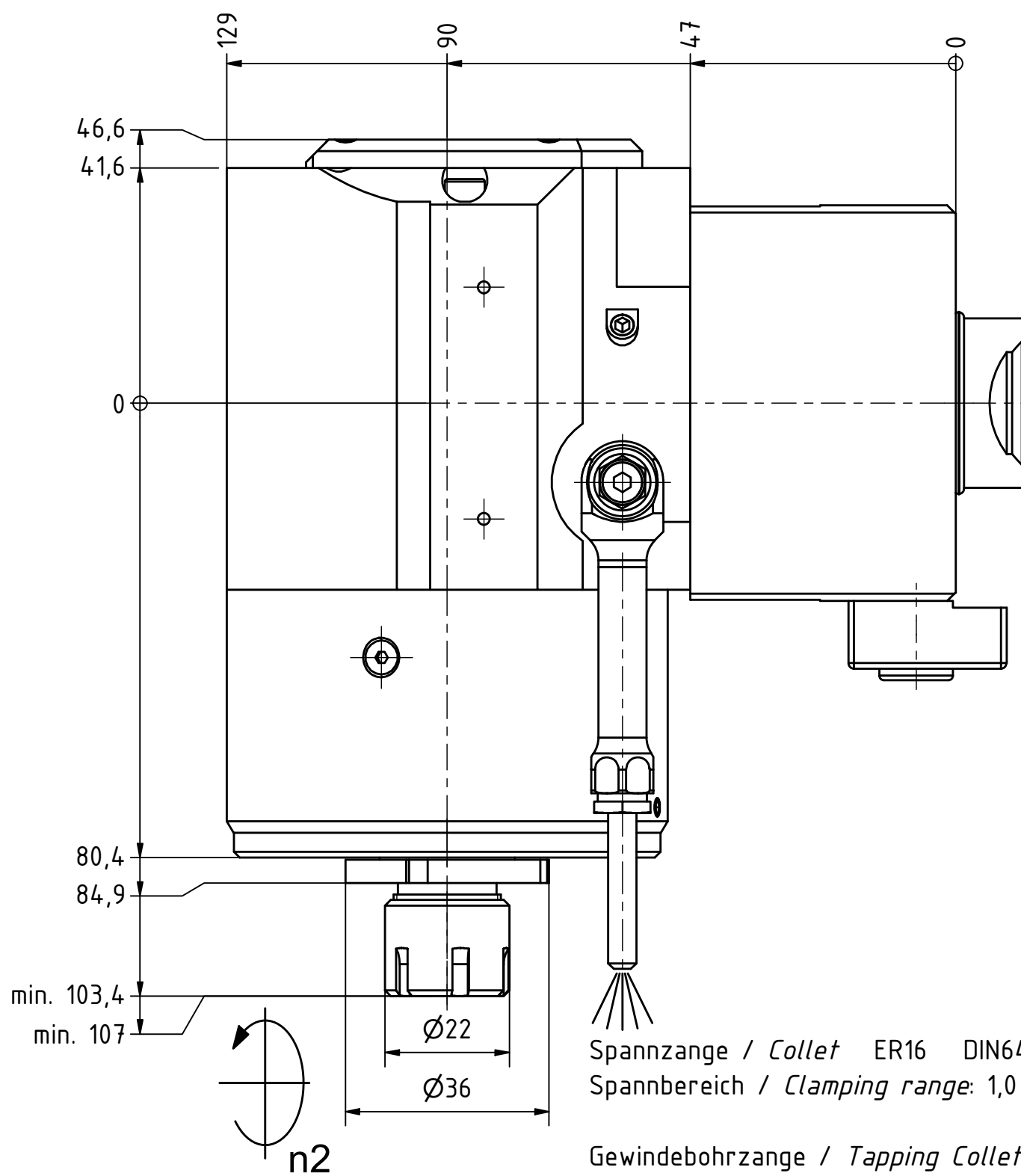

Spannzange / Collet ER16 DIN6499
Spannbereich / Clamping range: 1,0 - 10,0

Gewindebohrzange / Tapping Collet
ET-1-16 M1-M6

Fettschmierung mit Klüber Isoflex NCA 15
Alle 100 Betriebsstunden mit ca. 1cm³ Fett nachschmieren
Grease lubrication with Klüber Isoflex NCA 15
relubricate every 100 operating hours with about 1cm³ of grease

Copyright **EWS Tool Technologies**
Weitergabe und Vervielfältigung dieser Unterlage,
Verwertung und Mitteilung ihres Inhalts nicht
gestattet, soweit nicht ausdrücklich zugestanden.
Zu widerhandlungen verpflichten zu Schadenersatz.

<p>Bemerkung - Note</p>	<p>Technische Daten - technical data</p> <p>Weight = 6.153 [kg] Torque max. (M1/M2) = 25 / 5 [Nm] Speed max. (n1/n2) = 4800 / 24.000 [1/min] Gear ratio (i)=n1:n2 = 1:5</p>	<p>Benennung - Title</p> <p>Radial Bohr und Fräskopf Radial drilling and milling head</p>	<p>EWS Tool Technologies</p> <p>EWS Weigle GmbH & Co. KG Maybachstr. 1 D-73066 UHINGEN www.ews-tools.de</p> <p>Nr. - No. 60.3016G300RLI15V</p>	<p>Technische Änderungen vorbehalten! Subject to technical modifications!</p> <p>IDENT: DEWS256301</p> <p>REV: -/A</p> <p>MNR. 230799</p>	<p>QR</p>
-------------------------	---	---	--	--	------------------