

Spannzange / collet ER32 DIN6499
 Spannungsbereich / clamping range: 2,0 - 20,0

Gewindebohrzange / tapping collet
 ET-1-32 M5-M12

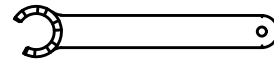

Spannzangenschlüssel für
 innenliegende Mutter
 Clamping wrench for
 internal collet
 232AX

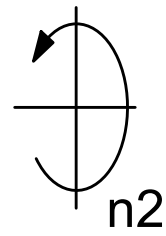
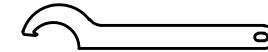

Hakenschlüssel
 mit Nase
 Hook wrench with
 nose end
 DIN1810 A 68x75



Butterfly
 Seal

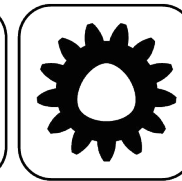

Polygon
 Joint

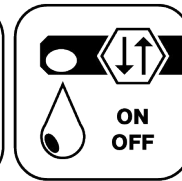

Coolant
 Management



Tech
 Details

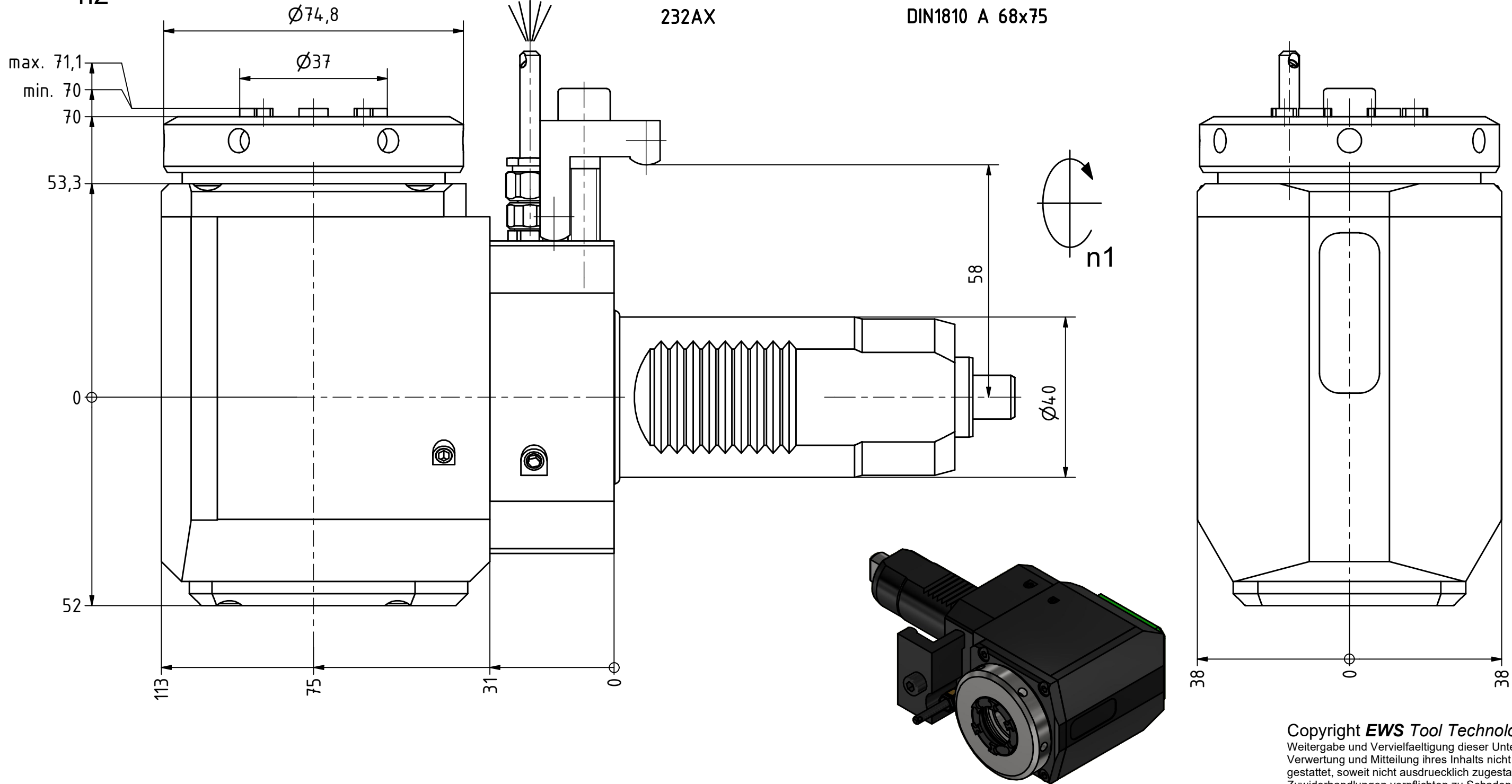

Copyright **EWS Tool Technologies**
 Weitergabe und Vervielfältigung dieser Unterlage,
 Verwertung und Mitteilung ihres Inhalts nicht
 gestattet, soweit nicht ausdrücklich zugestanden.
 Zuwiderhandlungen verpflichten zu Schadenersatz.

Bemerkung - Note

Technische Daten - technical data

Weight = 6.042 [kg]
 Torque max. (M1/M2) = 63 / 63 [Nm]
 Speed max. (n1/n2) = 6000 / 6000 [1/min]
 Gear ratio (i)=n1:n2 = 1:1

Benennung - Title

Radial Bohr und Fräskopf
Radial drilling and milling head



Nr. - No.

60.4032VL3LIM#01

EWS Weigele GmbH & Co. KG
 Maybachstr. 1
 D-73066 Uhingen
 www.ews-tools.de

Technische Änderungen vorbehalten!
 Subject to technical modifications!

IDENT: DEWS255635



REV: -/A

MNR.

230881

