

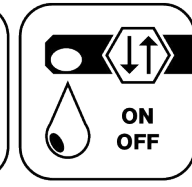

Butterfly Seal

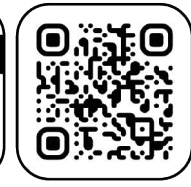

Coolant Management



Tech Details

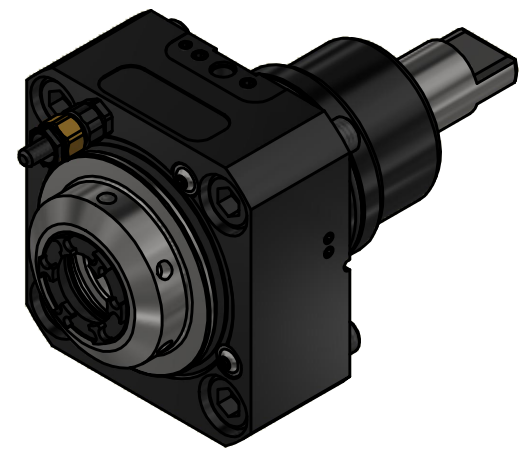
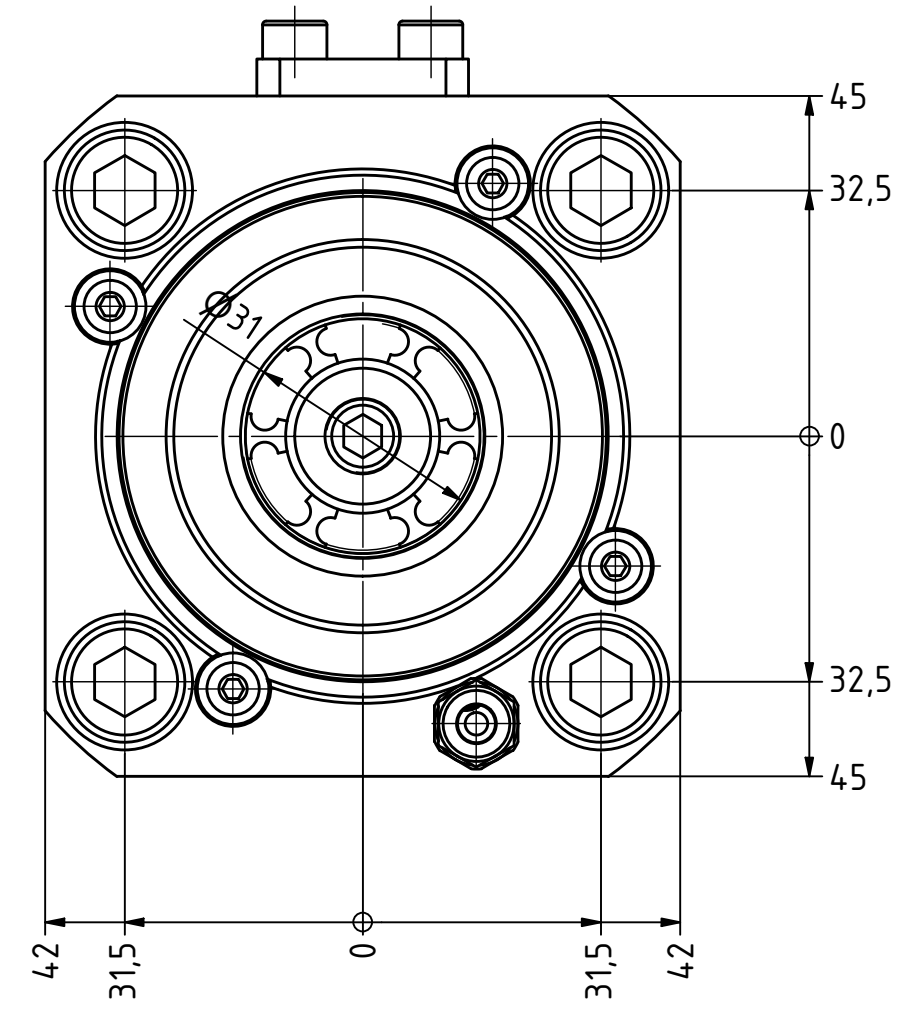
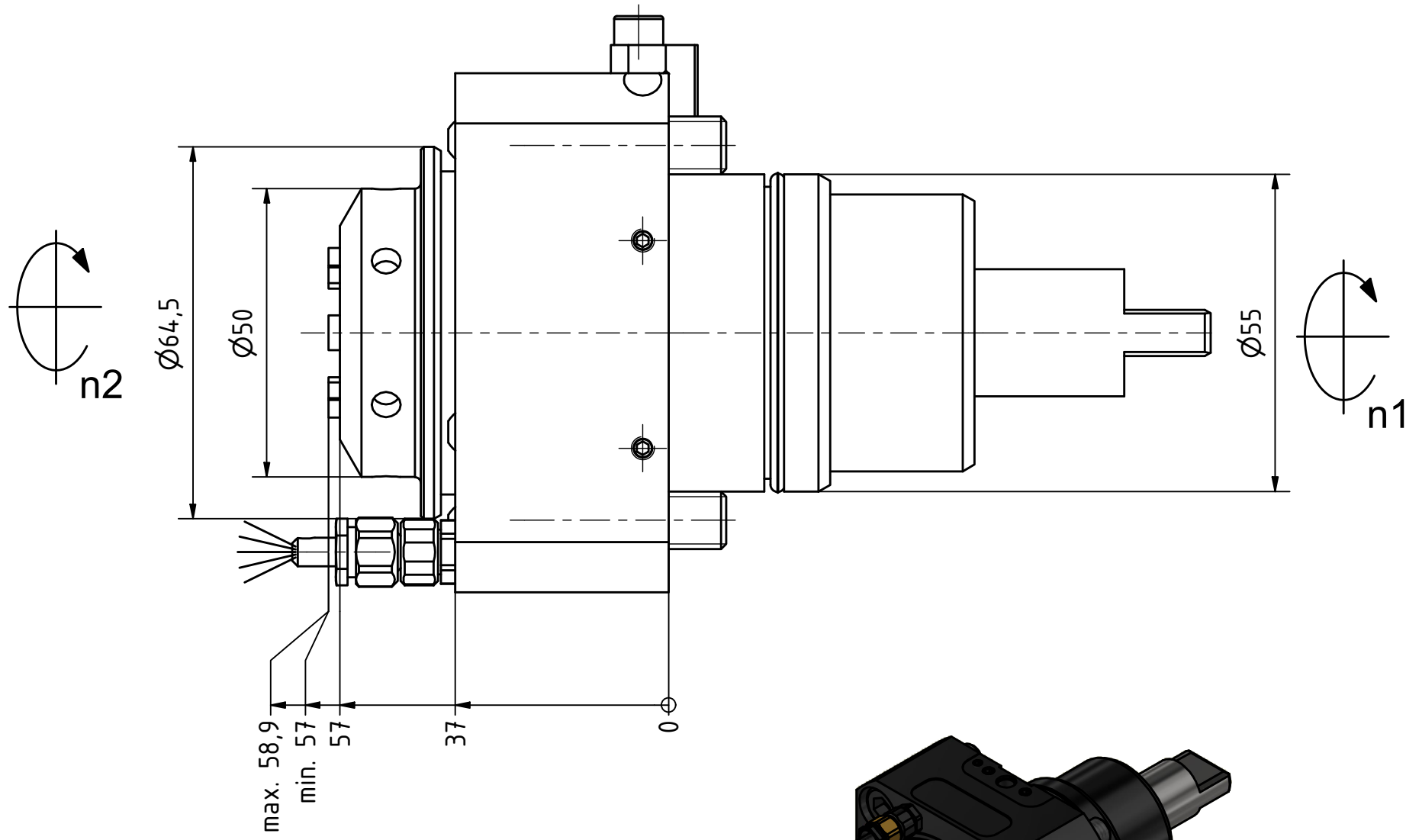

  
 Hakenschlüssel  
 mit Zapfen  
 Hook wrench  
 with fixed pin  
 DIN1810 B 45x50

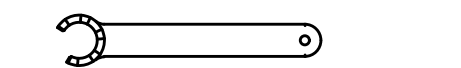
  
 Spannzangenschlüssel für  
 innenliegende Mutter  
 Clamping wrench for  
 internal collet  
 225AX

Spannzange / collet ER25 DIN6499  
 Spannbereich / clamping range: 1,0 - 16,0  
  
 Gewindebohrzange / tapping collet  
 ET-1-25 M3-M12

Copyright **EWS Tool Technologies**  
 Weitergabe und Vervielfältigung dieser Unterlage,  
 Verwertung und Mitteilung ihres Inhalts nicht  
 gestattet, soweit nicht ausdrücklich zugestanden.  
 Zuwiderhandlungen verpflichten zu Schadenersatz.

Bemerkung - Note

Technische Daten - technical data

Weight	= 2.902 [kg]
Torque max. (M1/M2)	= 63 / 63 [Nm]
Speed max. (n1/n2)	= 6000 / 6000 [1/min]
Gear ratio (i)=n1:n2	= 1:1

Benennung - Title

**Axial Bohr und Fräskopf**  
**Axial drilling and milling head**

**EWS** Tool Technologies  
 EWS Weigle GmbH & Co. KG  
 Maybachstr. 1  
 D-73066 UHINGEN  
 www.ews-tools.de

Technische Änderungen vorbehalten!  
 Subject to technical modifications!

IDENT: DEWS254786	REV: -/A
Nr. - No.	MNR.
<b>40.5525BIG1809IM#02</b>	<b>230689</b>

