

Spannzange / collet ER25 DIN6499
Spannbereich / clamping range: 1,0 - 16,0

Gewindebohrzange / tapping collet
ET-1-25 M3-M12

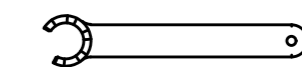

Spannzangenschlüssel für
innenliegende Mutter
Clamping wrench for
internal collet
225AX

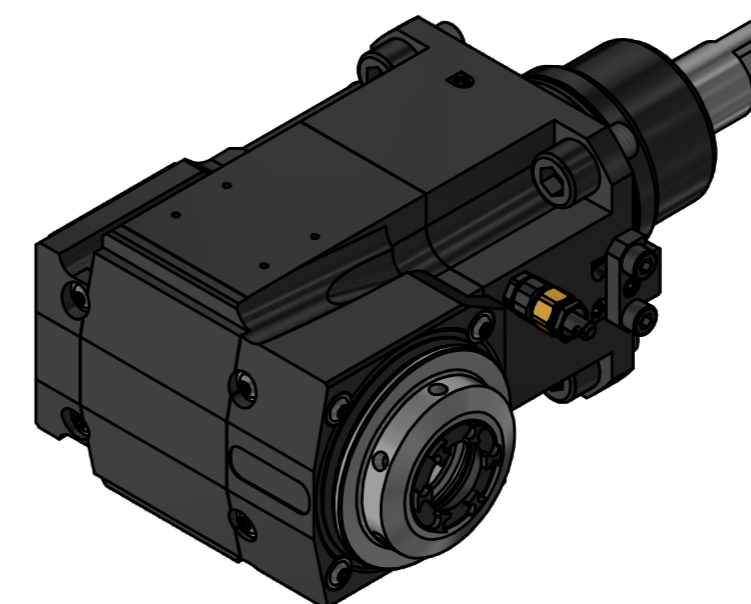
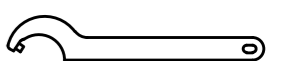

Hakenschlüssel
mit Zapfen
Hook wrench
with fixed pin
DIN1810 B 45x50

Copyright **EWS Tool Technologies**
Weitergabe und Vervielfältigung dieser Unterlage,
Verwertung und Mitteilung ihres Inhalts nicht
gestattet, soweit nicht ausdrücklich zugestanden.
Zuwerhandlungen verpflichten zu Schadenersatz.

Bemerkung - Note
mit Kegelrollenlager
with taper roller bearing(s)

Technische Daten - technical data
Weight = 7.029 [kg]
Torque max. (M1/M2) = 40 / 80 [Nm]
Speed max. (n1/n2) = 6000 / 3000 [1/min]
Gear ratio (i)=n1:n2 = 2:1

Benennung - Title
Radial Bohr und Fräskopf
Radial drilling and milling head

EWS Tool Technologies
EWS Weigle GmbH & Co. KG
Maybachstr. 1
D-73066 Ulm/ingen
www.ews-tool.de

Technische Änderungen vorbehalten!
Subject to technical modifications!
IDENT: DEWS254951

Nr. - No.
60.5525KRBIG1809GLI2IMX100

REV: -/A
MNR.
230721

