

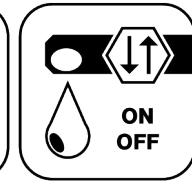

Butterfly Seal

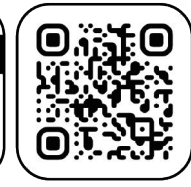

Coolant Management



Tech Details

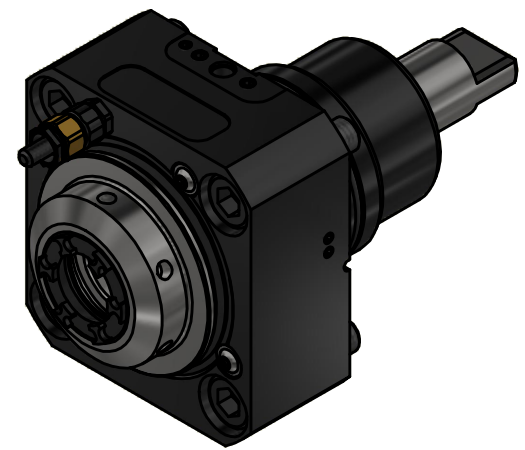
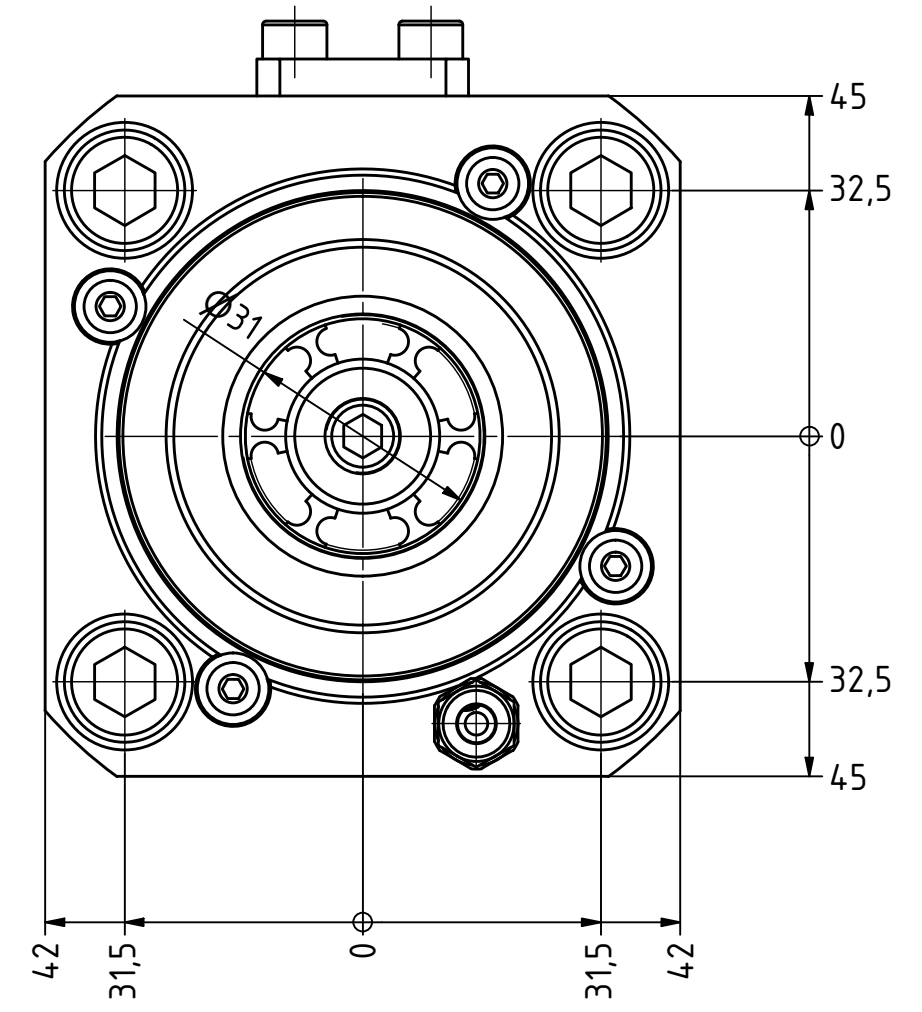
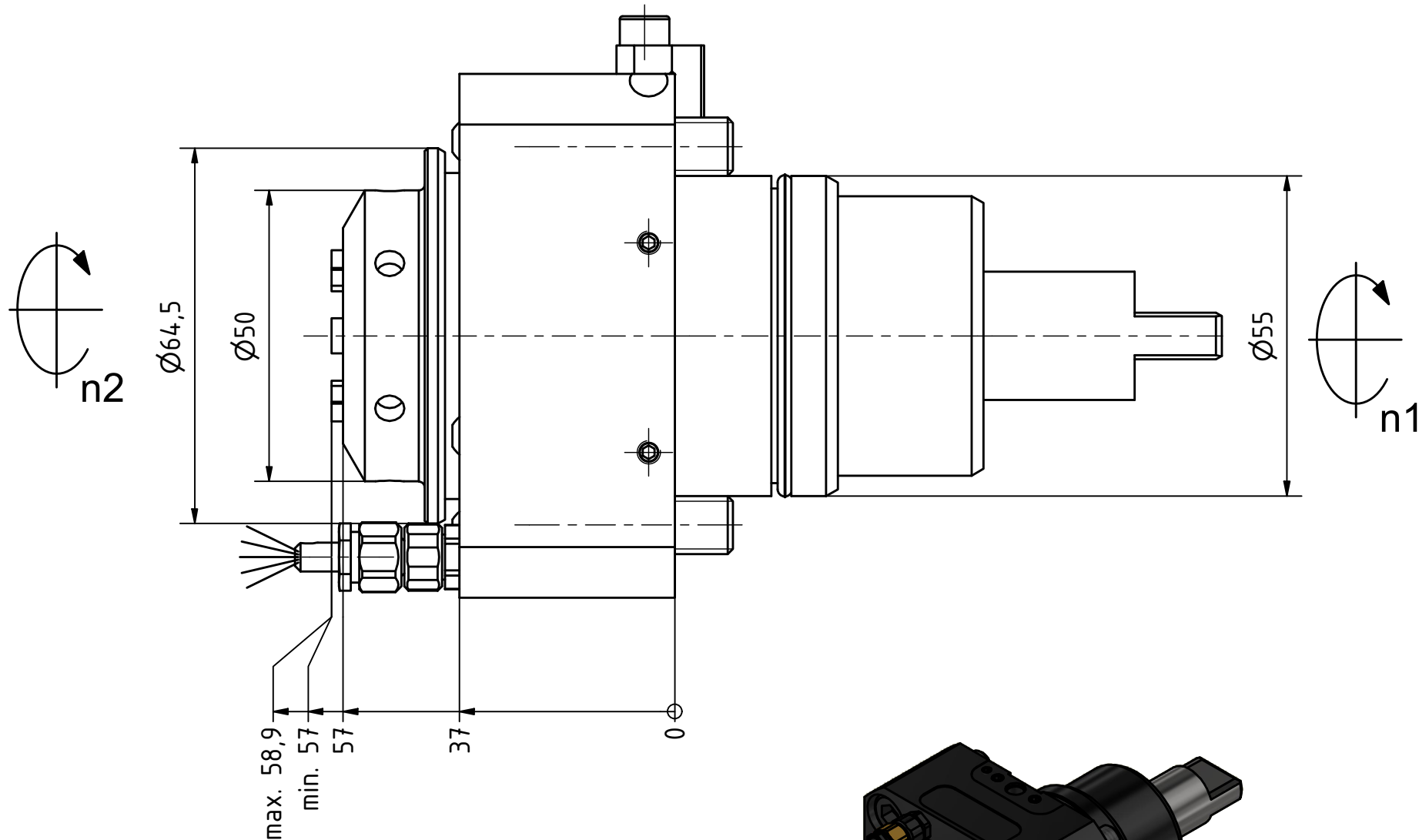

Spannzange / collet ER25 DIN6499  
 Spannungsbereich / clamping range: 1,0 - 16,0

Gewindebohrzange / tapping collet  
 ET-1-25 M3-M12

  
 Hakenschlüssel  
 mit Zapfen  
 Hook wrench  
 with fixed pin  
 DIN1810 B 45x50

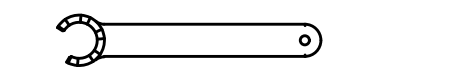
  
 Spannzangenschlüssel für  
 innenliegende Mutter  
 Clamping wrench for  
 internal collet  
 225AX

Copyright **EWS Tool Technologies**  
 Weitergabe und Vervielfältigung dieser Unterlage,  
 Verwertung und Mitteilung ihres Inhalts nicht  
 gestattet, soweit nicht ausdrücklich zugestanden.  
 Zuwiderhandlungen verpflichten zu Schadenersatz.

Bemerkung - Note  
 mit Kegelrollenlager  
 with taper roller bearing(s)

Technische Daten - technical data  
 Weight = 2.966 [kg]  
 Torque max. (M1/M2) = 63 / 63 [Nm]  
 Speed max. (n1/n2) = 5000 / 5000 [1/min]  
 Gear ratio (i)=n1:n2 = 1:1

Benennung - Title

**EWS** Tool Technologies  
 EWS Weigle GmbH & Co. KG  
 Maybachstr. 1  
 D-73066 UHINGEN  
 www.ews-tools.de

Technische Änderungen vorbehalten!  
 Subject to technical modifications!  
 IDENT: DEWS254896  
 Nr. - No. 40.5525KRBIG1809IM

REV: -/A  
 MNR. 230693

