

Spannzange / collet ER25 DIN6499
Spannbereich / clamping range: 1,0 - 16,0

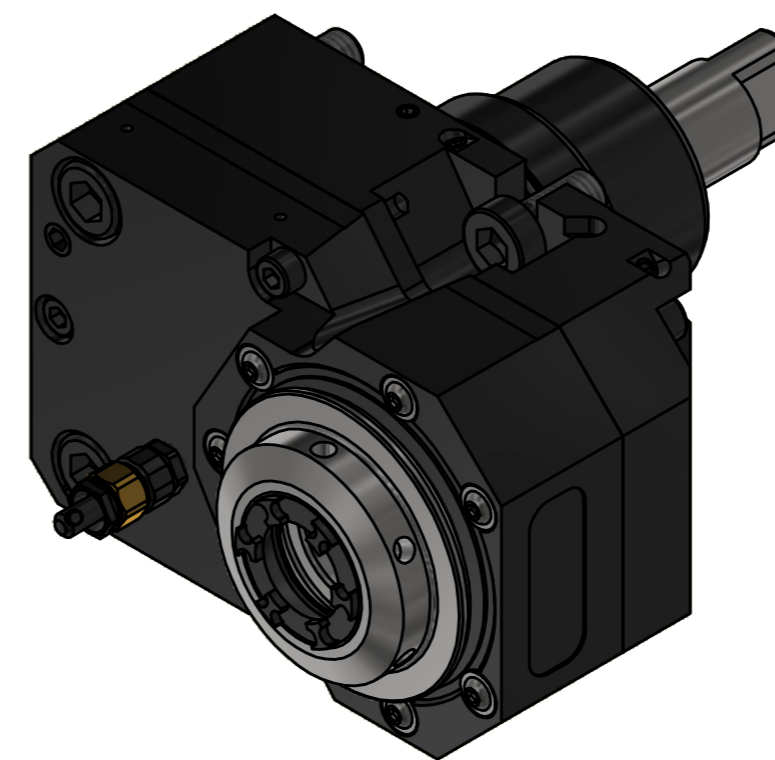

 Spannzangenschlüssel für innenliegende Mutter
Clamping wrench for internal collet
225AX

 Hakenschlüssel mit Nase
Hook wrench with nose end
DIN1810 A 45x50

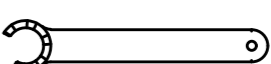
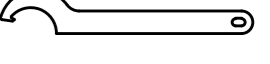
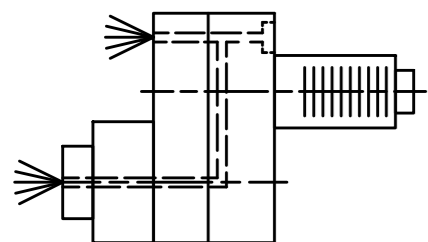

Innen- und Aussenkuehlung / Inside and outside coolant supply
Kuehlmittefilterierung+50µ / coolant filtration+50µ

<p>Bezeichnung - Note Für Trockenlauf geeignet! Use without coolant fluid allowed!</p>	<p>Technische Daten - technical data Weight = 5.283 [kg] Torque max. (M1/M2) = 50 / 25 [Nm] Speed max. (n1/n2) = 6000 / 12000 [1/min] Gear ratio (i)=n1:n2 = 1:2 Pressure (pmax) = 70 [bar]</p>	<p>Benennung - Title Axial Bohr u. Fräskopf achsversetzt Ax. drill. and mill. head offset</p>	<p>EWS Tool Technologies EWS Weigle GmbH & Co. KG Maybachstr. 1 D-73066 Ulm/ingen www.ews-tools.de</p>	<p>Technische Änderungen vorbehalten! Subject to technical modifications! IDENT: DEWS255971</p>	<p>Nr. - No. 50.5525BIG1809IKD11M</p>	<p>REV: -/A MNR. 230935</p>
--	---	---	---	---	---	-------------------------------------



Copyright **EWS Tool Technologies**
Weitergabe und Vervielfältigung dieser Unterlage,
Verwertung und Mitteilung ihres Inhalts nicht
gestattet, soweit nicht ausdrücklich zugestanden.
Zu widerhandlungen verpflichten zu Schadenersatz.