

Schwenkbereich $\pm 92^\circ$
Swivel area $\pm 92^\circ$

Spannzange / Collet ER16 DIN6499
Spannbereich / Clamping range: 1,0 - 10,0

Gewindebohrzange / Tapping Collet
ET-1-16 M1-M6

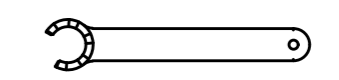
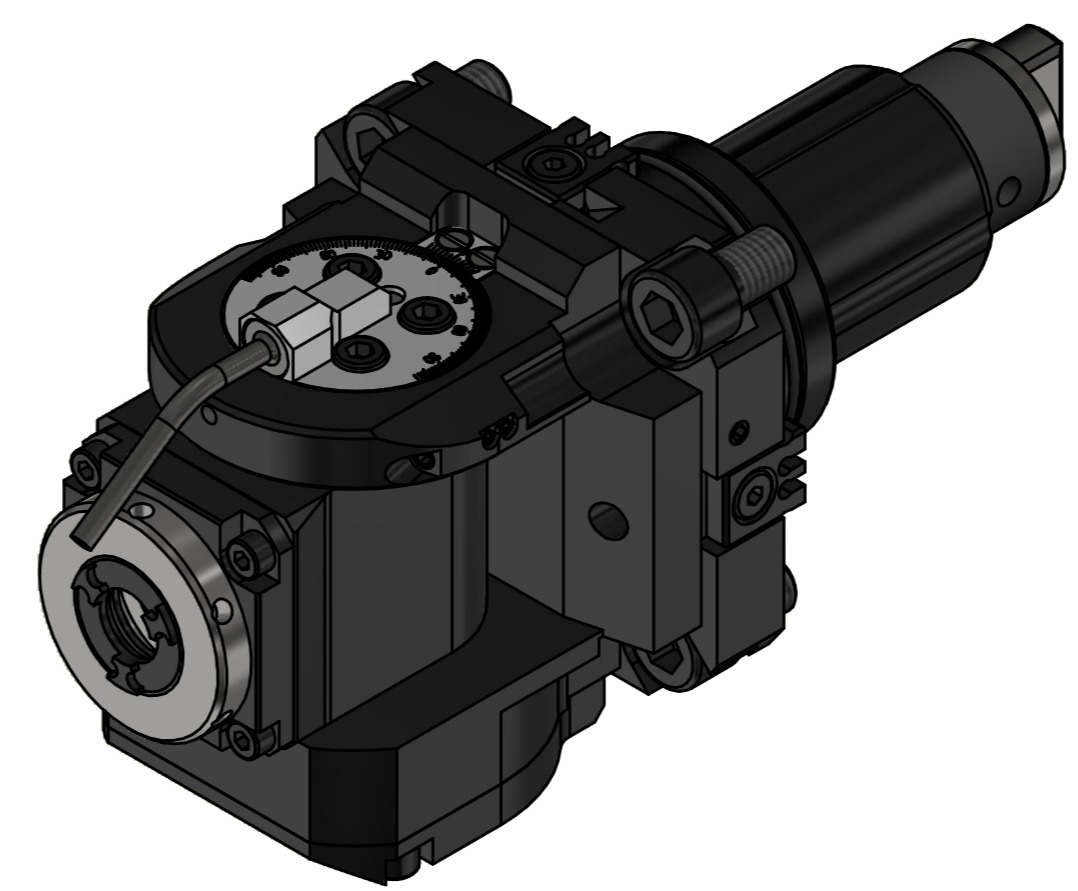

Spannzangenschlüssel für
innenliegende Mutter
Clamping wrench for
internal collet
216AX

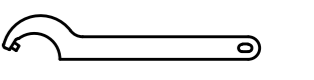

Hakenschlüssel
mit Zapfen
Hook wrench
with fixed pin
DIN1810 B 40x42

Copyright **EWS Tool Technologies**
Weitergabe und Vervielfältigung dieser Unterlage,
Verwertung und Mitteilung ihres Inhalts nicht
gestattet, soweit nicht ausdrücklich zugestanden.
Zuwendungen verpflichten zu Schadenersatz.

Eine Nachbarstation könnte entfallen!
A neighbouring station may be lost!

Bemerkung - Note	Technische Daten - technical data Weight = 4,746 [kg] Torque max. (M1/M2) = 16 / 16 [Nm] Speed max. (n1/n2) = 6000 / 6000 [1/min] Gear ratio (i)=n1:n2 = 1:1	Benennung - Title Schwenkkopf Swivel head	 EWS Weigle GmbH & Co. KG Maybachstr. 1 D-73066 Uhingen www.ews-tools.de Nr. - No. 63.55161809PFIM	Technische Änderungen vorbehalten! Subject to technical modifications! IDENT: DEWS255871 MNR. 230898	
------------------	--	---	--	---	---