

Spannzange / collet ER25 DIN6499  
Spannbereich / clamping range: 1,0 - 16,0

Gewindebohrzange / tapping collet  
ET-1-25 M3-M10

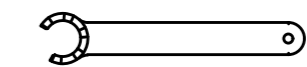

Spannzangenschlüssel für  
innenliegende Mutter  
Clamping wrench for  
internal collet  
225AX

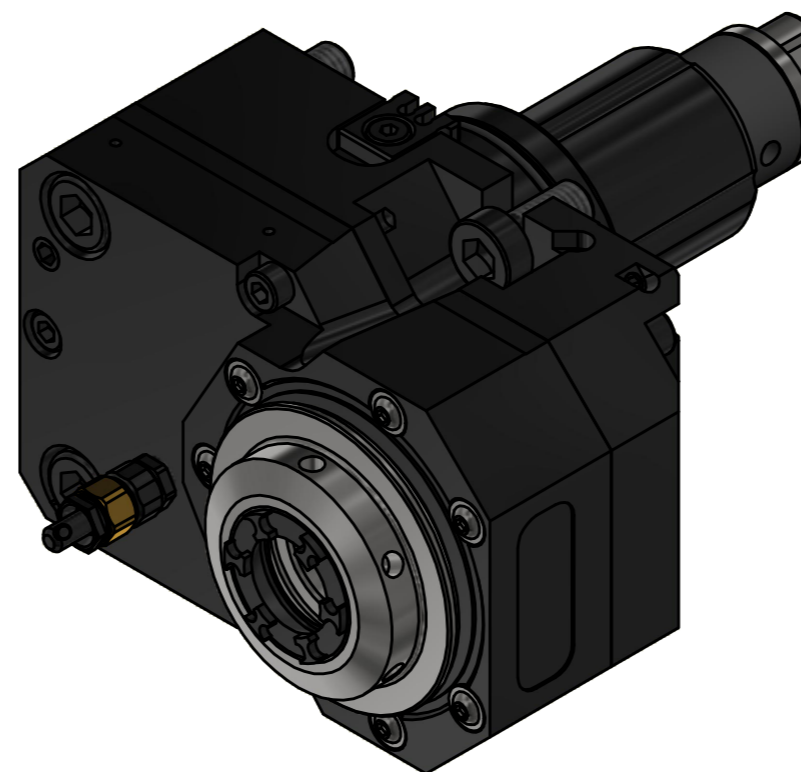
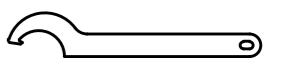

Hakenschlüssel  
mit Nase  
Hook wrench with  
nose end  
DIN1810 A 45x50

Copyright **EWS Tool Technologies**  
Weitergabe und Vervielfältigung dieser Unterlage,  
Verwertung und Mitteilung ihres Inhalts nicht  
gestattet, soweit nicht ausdrücklich zugestanden.  
Zuwendungen verpflichten zu Schadenersatz.

Bemerkung - Note	Technische Daten - technical data <b>Weight</b> = 6.221 [kg] <b>Torque max.</b> (M1/M2) = 63 / 63 [Nm] <b>Speed max.</b> (n1/n2) = 6000 / 6000 [1/min] <b>Gear ratio</b> (i)=n1:n2 = 1:1	Benennung - Title <b>Axial Bohr u. Fräskopf achsversetzt</b> <b>Ax. drill. and mill. head offset</b>	 EWS Weigle GmbH & Co. KG Maybachstr. 1 D-73066 Uhlingen www.ews-tools.de	Technische Änderungen vorbehalten! Subject to technical modifications! IDENT: DEWS255764 REV: -/A	 MNR. <b>230911</b>
------------------	--	--	---	--	---------------------------