

Spannzange / collet ER25 DIN6499  
 Spannbereich / clamping range: 1,0 - 16,0

Gewindebohrzange / tapping collet  
 ET-1-25 M3-M10

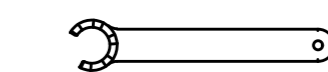

Spannzangenschlüssel für  
 innenliegende Mutter  
*Clamping wrench for  
 internal collet*  
 225AX

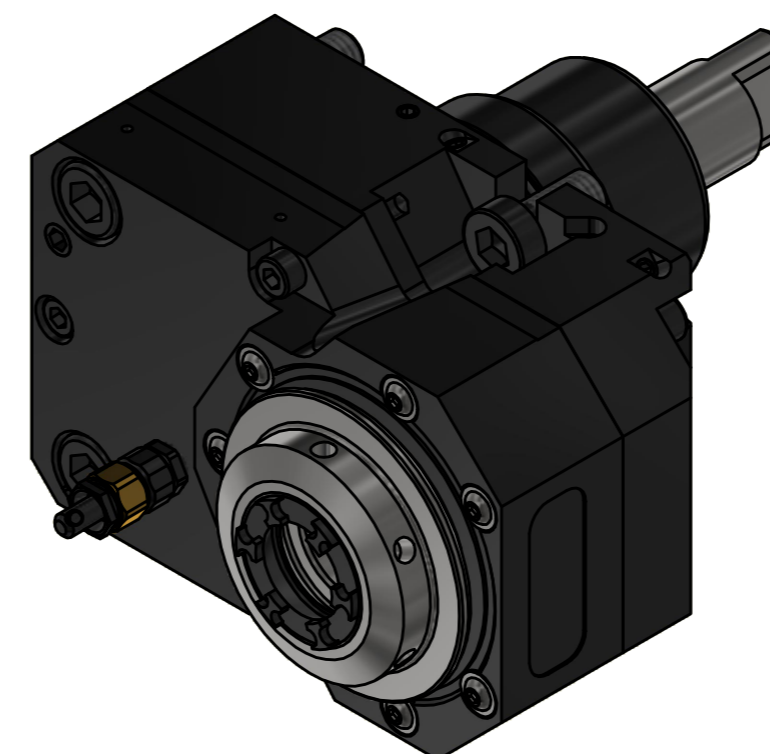
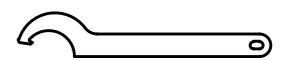

Hakenschlüssel  
 mit Nase  
*Hook wrench with  
 nose end*  
 DIN1810 A 45x50

Copyright **EWS Tool Technologies**  
 Weitergabe und Vervielfältigung dieser Unterlage,  
 Verwertung und Mitteilung ihres Inhalts nicht  
 gestattet, soweit nicht ausdrücklich zugestanden.  
 Zuwiderhandlungen verpflichten zu Schadenersatz.

Bemerkung - Note	Technische Daten - technical data <b>Weight</b> = 5,271 [kg] <b>Torque max.</b> (M1/M2) = 50 / 25 [Nm] <b>Speed max.</b> (n1/n2) = 6000 / 12000 [1/min] <b>Gear ratio</b> (i)=n1:n2 = 1:2	Benennung - Title <b>Axial Bohr u. Fräskopf achsversetzt</b> <b>Ax. drill. and mill. head offset</b>	 EWS Weigela GmbH & Co. KG Maybachstr. 1 D-73066 Uhlingen www.ews-tools.de	Technische Änderungen vorbehalten! Subject to technical modifications! IDENT: DEWS255964 Nr. - No. <b>50.5525BIG180911M</b>	MNR. <b>230934</b>	
------------------	---	--	--	---	-----------------------	--