

Spannzange / collet ER25 DIN6499  
Spannbereich / clamping range: 1,0 - 16,0

Gewindebohrzange / tapping collet  
ET-1-25 M3-M12

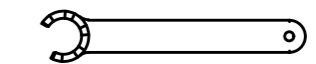

Spannzangenschlüssel für  
innenliegende Mutter  
Clamping wrench for  
internal collet  
225AX

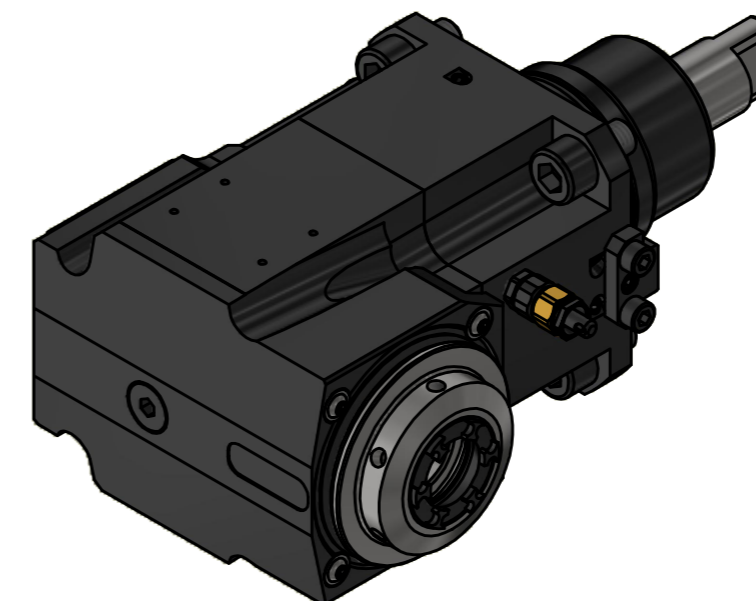
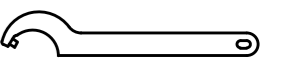

Hakenschlüssel  
mit Zapfen  
Hook wrench  
with fixed pin  
DIN1810 B 45x50

Copyright **EWS Tool Technologies**  
Weitergabe und Vervielfältigung dieser Unterlage,  
Verwertung und Mitteilung ihres Inhalts nicht  
gestattet, soweit nicht ausdrücklich zugestanden.  
Zuwendungen verpflichten zu Schadenersatz.

Bemerkung - Note  
mit Kegelrollenlager  
with taper roller bearing(s)

Technische Daten - technical data  
Weight = 7.485 [kg]  
Torque max. (M1/M2) = 63 / 63 [Nm]  
Speed max. (n1/n2) = 5000 / 5000 [1/min]  
Gear ratio (i)=n1:n2 = 1:1

Benennung - Title  
**Radial Bohr und Fräskopf**  
**Radial drilling and milling head**

**EWS** Tool Technologies  
EWS Weigle GmbH & Co. KG  
Maybachstr. 1  
D-73066 Ulm/Ingen  
www.ews-tool.de

Technische Änderungen vorbehalten!  
Subject to technical modifications!  
IDENT: DEWS254932

Nr. - No.  
60.5525KRBIG1809GLIMX100

REV: -/A  
MNR.

230719

