

Spannzange / collet ER25 DIN6499  
Spannbereich / clamping range: 1,0 - 16,0

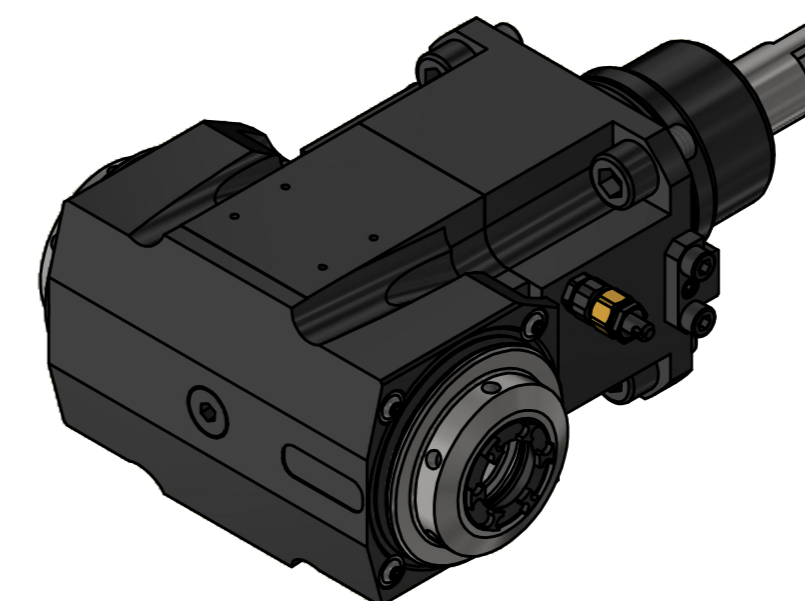

Gewindebohrzange / tapping collet ET-1-25 M3-M12



Spannzangenschlüssel für innenliegende Mutter  
Clamping wrench for internal collet  
225AX

Hakenschlüssel mit Zapfen  
Hook wrench with fixed pin  
DIN1810 B 45x50

Copyright EWS Tool Technologies  
Weitergabe und Vervielfältigung dieser Unterlage, Verwertung und Mitteilung ihres Inhalts nicht gestattet, soweit nicht ausdrücklich zugestanden. Zuwiderhandlungen verpflichten zu Schadenersatz.

Bemerkung - Note	Technische Daten - technical data Weight = 8.132 [kg] Torque max. (M1/M2) = 63 / 63   63 [Nm] Speed max. (n1/n2) = 6000 / 6000   6000 [1/min] Gear ratio (i)=n1:n2 = 1:1   1:1	Benennung - Title <b>Radial Bohr und Fräskopf</b> <b>Radial drilling and milling head</b>	 EWS Weigle GmbH & Co. KG Maybachstr. 1 D-73066 Ulm/Ingen www.ews-tools.de Technische Änderungen vorbehalten! Subject to technical modifications! IDENT: DEWS255063 Nr. - No. 60.5525DBIG1809IMX100 MNR. 230726 REV: -/A 
------------------	--	---	---