

Innen- und Aussenkuehlung / Inside and outside coolant supply
Kuehlmittelfiltrierung 50μ / coolant filtration 50μ

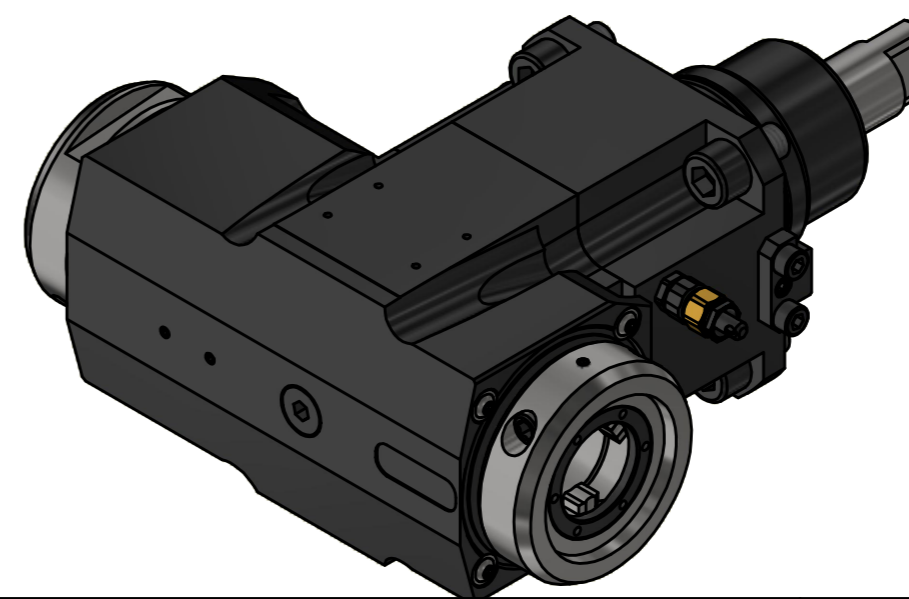

Copyright **EWS Tool Technologies**
Weitergabe und Vervielfaeltigung dieser Unterlage,
Verwertung und Mitteilung ihres Inhalts nicht
gestattet, soweit nicht ausdrecklich zugestanden.
Zuwoiderhandlungen verpflichten zu Schadensersatz.

| | | | |
|--|--|--|---|
| <p>Bemerkung - Note Für Trockenlauf geeignet! Use without coolant fluid allowed!</p> | <p>Technische Daten - technical data Weight = 9.327 [kg] Torque max. (M1/M2) = 63 / 63 63 [Nm] Speed max. (n1/n2) = 6000 / 6000 6000 [1/min] Gear ratio (i)=n1:n2 = 1:1 1:1 Pressure (pmax) = 70 [bar]</p> | <p>Benennung - Title Radial Bohr und Fräskopf Radial drilling and milling head</p> | <p>EWS Tool Technologies EWS Weigle GmbH & Co. KG Maybachstr. 1 D-73066 Uhingen www.ews-tools.de</p> <p>Technische Aenderungen vorbehalten! Subject to technical modifications! IDENT: DEWS255479</p> <p>Nr. - No. 60.55VX3DBIG1809IKDX100#01</p> <p>REV: -/A MNR. 230736</p> <div style="float: right; font-size: 2em;">QR</div> |
|--|--|--|---|