

Spannzange / collet ER25 DIN6499  
Spannbereich / clamping range: 1,0 - 16,0

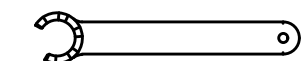

Spannzangenschlüssel für innenliegende Mutter  
Clamping wrench for internal collet  
225AX

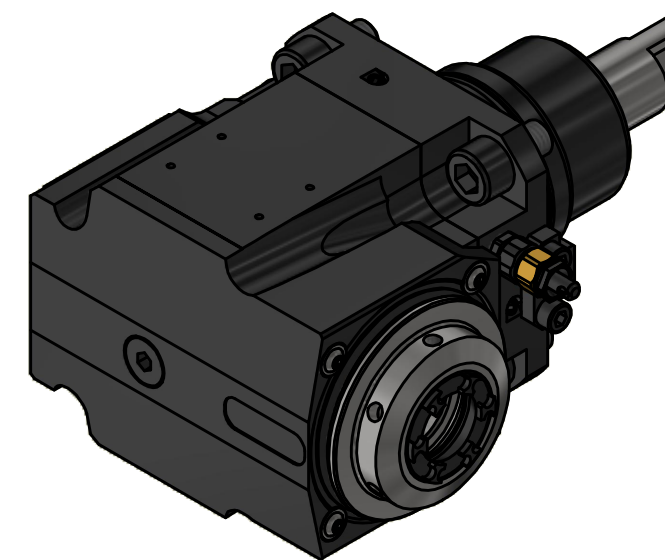
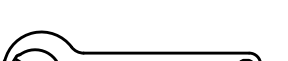

Hakenschlüssel mit Zapfen  
Hook wrench with fixed pin  
DIN1810 B 45x50

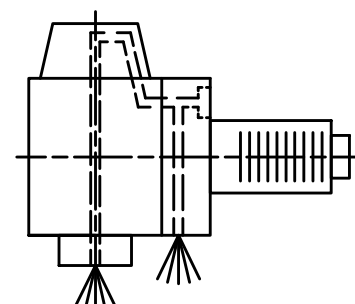

Innen- und Aussenkuehlung / Inside and outside coolant supply  
Kuehlmittelfiltrierung-50µ / coolant filtration-50µ

Copyright **EWS Tool Technologies**  
Weitergabe und Vervielfaeltigung dieser Unterlage, Verwertung und Mitteilung ihres Inhalts nicht gestattet, soweit nicht ausdruecklich zugestanden. Zuwiderhandlungen verpflichten zu Schadenersatz.

<p>Bemerkung - Note Für Trockenlauf geeignet! Use without coolant fluid allowed! mit Kegelrollenlager with taper roller bearing(s)</p>	<p>Technische Daten - technical data Weight = 6.224 [kg] Torque max. (M1/M2) = 63 / 63 [Nm] Speed max. (n1/n2) = 5000 / 5000 [1/min] Gear ratio (i)=n1:n2 = 1:1 Pressure (pmax) = 70 [bar]</p>	<p>Benennung - Title <b>Radial Bohr und Fräskopf</b> <b>Radial drilling and milling head</b></p>	<p><b>EWS</b> Tool Technologies EWS Weigle GmbH &amp; Co. KG Maybachstr. 1 D-73066 Uhingen www.ews-tools.de</p> <p>Technische Aenderungen vorbehalten! Subject to technical modifications! IDENT: DEWS255126 REV: -/A MNR. 230700</p> <p>Nr. - No. 60.5525KRBIG1809IKDGLIMX70</p> <p><b>QR</b></p>
--	--	--	--