

Spannzange / collet ER25 DIN6499
Spannbereich / clamping range: 1,0 - 16,0

Spannzange / collet ER25 DIN6499
Spannbereich / clamping range: 1,0 - 16,0

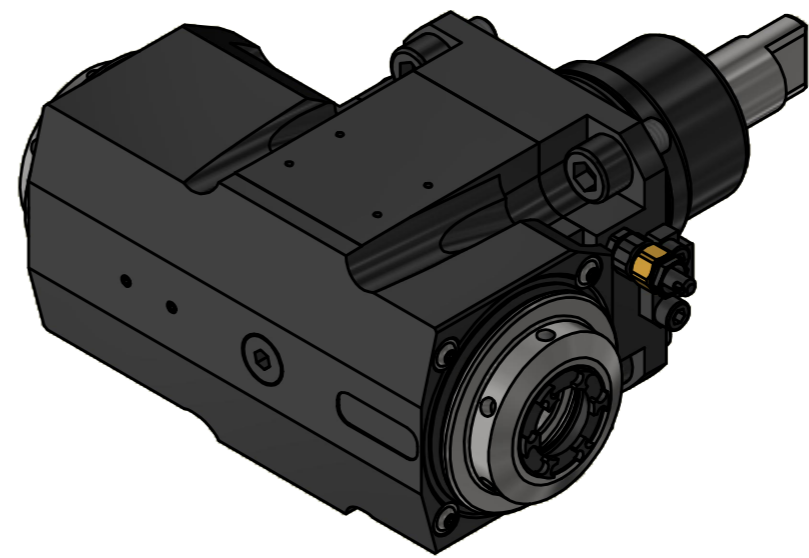
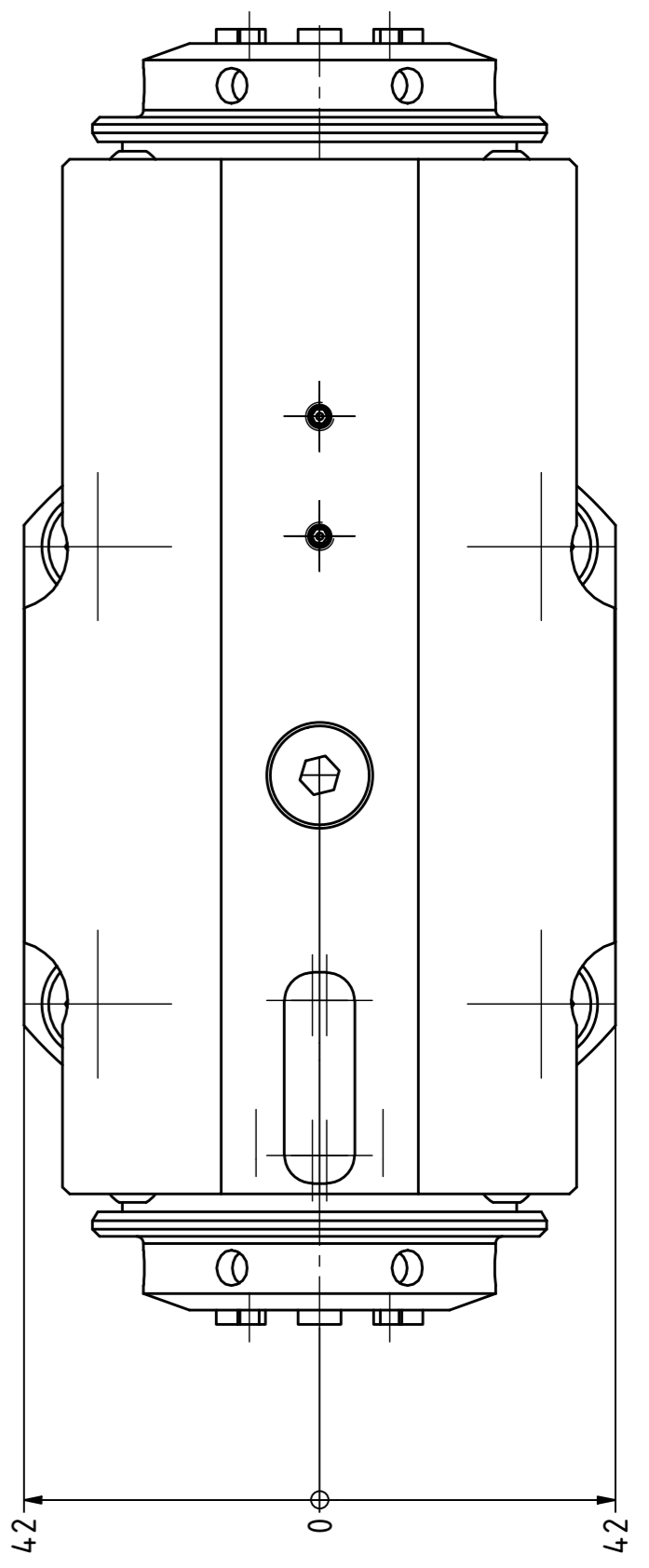
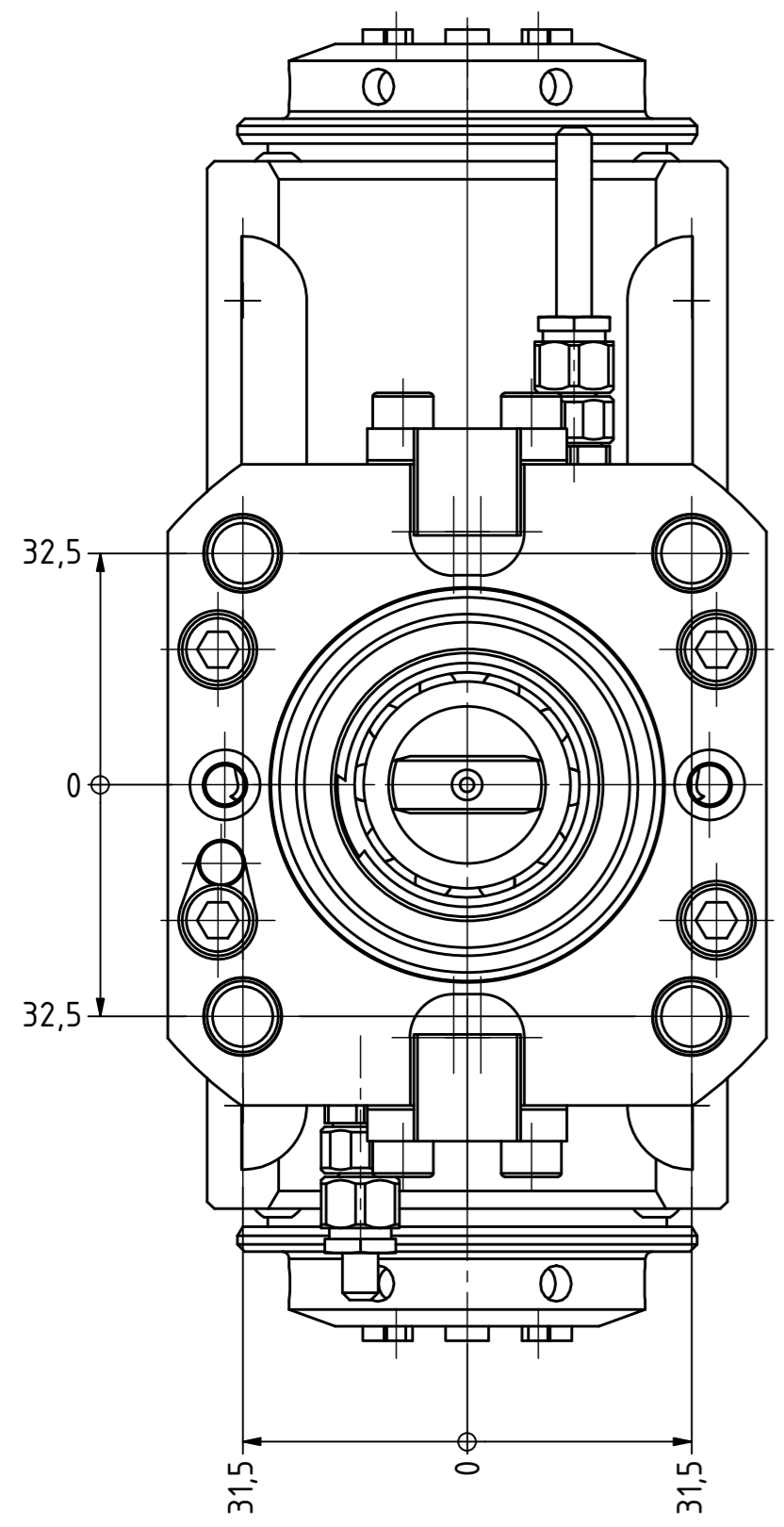

Spannzangenschlüssel für innenliegende Mutter
Clamping wrench for internal collet
225AX

Hakenschlüssel mit Zapfen
Hook wrench with fixed pin
DIN1810 B 45x50

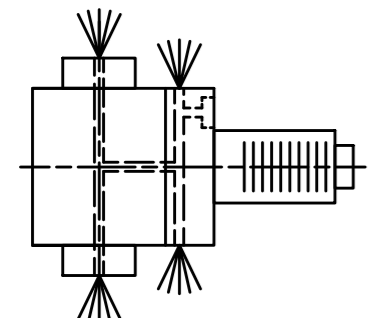

Innen- und Aussenkuehlung / Inside and outside coolant supply
Kein Trockenlauf / No dry run
Kuehlmittelfiltrierung=50µ / coolant filtration=50µ

Copyright **EWS Tool Technologies**
Weitergabe und Vervielfaeltigung dieser Unterlage,
Verwertung und Mitteilung ihres Inhalts nicht
gestattet, soweit nicht ausdrecklich zugestanden.
Zuwaerhandlungen verpflichten zu Schadenersatz.

<p>Bemerkung - Note Für Trockenlauf geeignet! Use without coolant fluid allowed!</p>	<p>Technische Daten - technical data Weight = 7.765 [kg] Torque max. (M1/M2) = 63 / 63 [Nm] Speed max. (n1/n2) = 6000 / 6000 6000 [1/min] Gear ratio (i)=n1:n2 = 1:1 1:1 Pressure (pmax) = 25 [bar]</p>	<p>Benennung - Title Radial Bohr und Fräskopf Radial drilling and milling head</p>	<p>EWS Tool Technologies EWS Weigle GmbH & Co. KG Maybachstr. 1 D-73066 Uhlingen www.ews-tool.de</p> <p>Technische Aenderungen vorbehalten! Subject to technical modifications! IDENT: DEWS255167 REV: -/A MNR. 230705</p> <p>Nr. - No. 60.5525DBIG1809IKDIMX70</p> <p>QR</p>
--	---	--	---