

Spannzange / collet ER25 DIN6499
 Spannereich / clamping range: 1,0 - 16,0

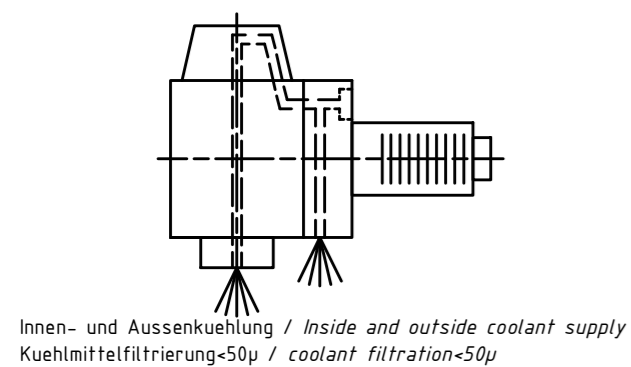
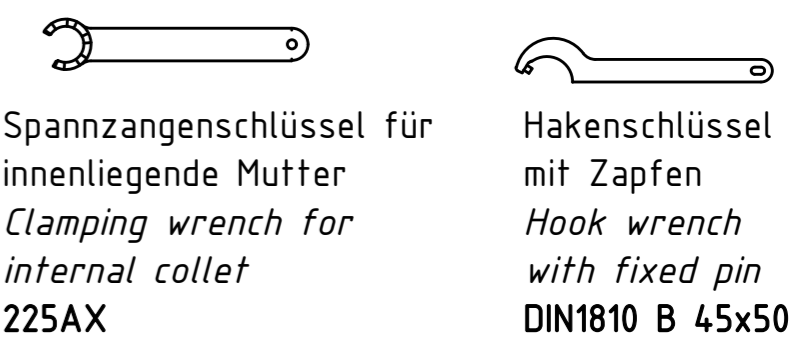
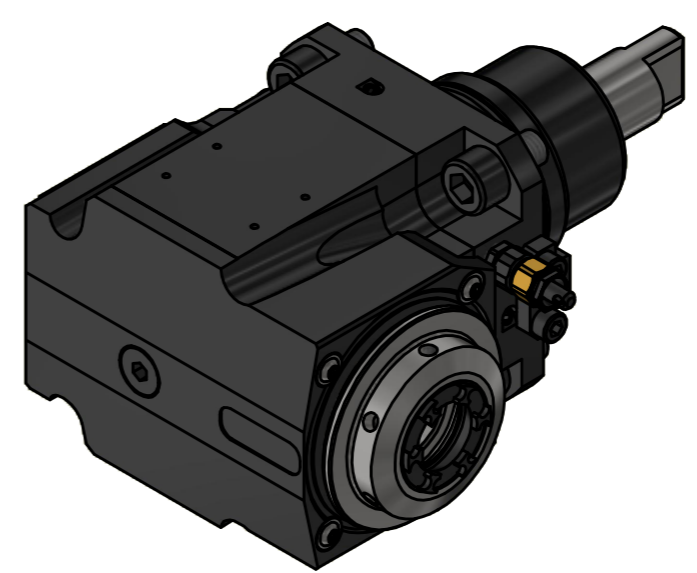

Innen- und Aussenkuehlung / Inside and outside coolant supply
 Kuehlmittelfiltrierung=50µ / coolant filtration=50µ

Bemerkung - Note Für Trockenlauf geeignet! Use without coolant fluid allowed!	Technische Daten - technical data Weight = 6.198 [kg] Torque max. (M1/M2) = 63 / 63 [Nm] Speed max. (n1/n2) = 6000 / 6000 [1/min] Gear ratio (i)=n1:n2 = 1:1 Pressure (pmax) = 70 [bar]	Benennung - Title Radial Bohr und Fräskopf Radial drilling and milling head	<table border="1"> <tr> <td data-bbox="2226 1911 2463 1984"> EWS <small>EWS Weigle GmbH & Co. KG Maybachstr. 1 D-73066 Uhlingen www.ews-tool.de</small> </td> <td data-bbox="2463 1911 2700 1984"> Technische Aenderungen vorbehalten! Subject to technical modifications! IDENT: DEWS255104 </td> <td data-bbox="2700 1911 2923 1984"> REV: -/A MNR. </td> </tr> <tr> <td data-bbox="2226 1984 2463 2047"> Nr. - No. 60.5525BIG1809IKDGLIMX70 </td> <td colspan="2" data-bbox="2463 1984 2923 2047"> 230698 </td> </tr> </table>	EWS <small>EWS Weigle GmbH & Co. KG Maybachstr. 1 D-73066 Uhlingen www.ews-tool.de</small>	Technische Aenderungen vorbehalten! Subject to technical modifications! IDENT: DEWS255104	 REV: -/A MNR.	Nr. - No. 60.5525BIG1809IKDGLIMX70	230698	
EWS <small>EWS Weigle GmbH & Co. KG Maybachstr. 1 D-73066 Uhlingen www.ews-tool.de</small>	Technische Aenderungen vorbehalten! Subject to technical modifications! IDENT: DEWS255104	 REV: -/A MNR.							
Nr. - No. 60.5525BIG1809IKDGLIMX70	230698								

Copyright **EWS Tool Technologies**
 Weitergabe und Vervielfaeltigung dieser Unterlage,
 Verwertung und Mitteilung ihres Inhalts nicht
 gestattet, soweit nicht ausdrecklich zugestanden.
 Zuwiderhandlungen verpflichten zu Schadenersatz.

