

Spannzange / collet ER25 DIN6499
Spannbereich / clamping range: 1,0 - 16,0

Gewindebohrzange / tapping collet
ET-1-25 M3-M12

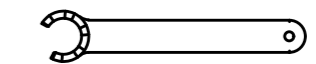

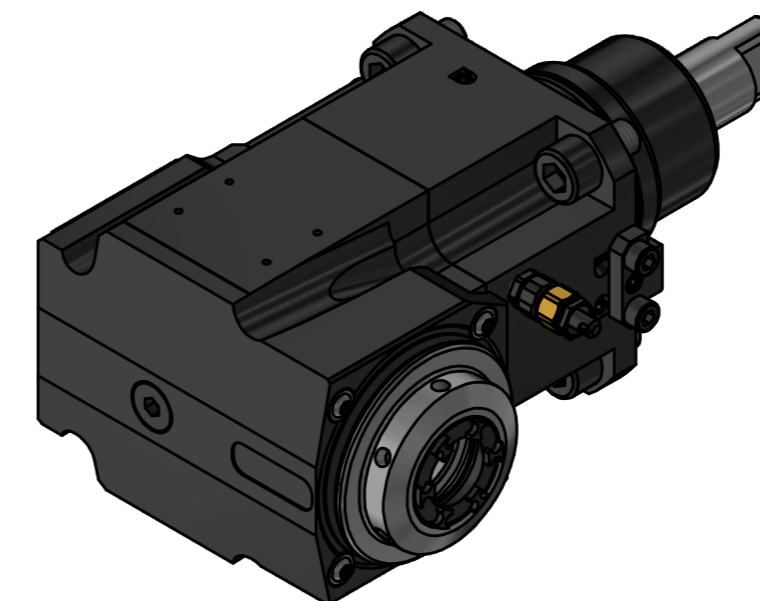
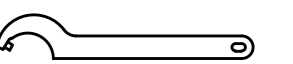

Spannzangenschlüssel für innenliegende Mutter
Clamping wrench for internal collet
225AX



Hakenschlüssel mit Zapfen
Hook wrench with fixed pin
DIN1810 B 45x50

Copyright **EWS Tool Technologies**
Weitergabe und Vervielfältigung dieser Unterlage, Verwertung und Mitteilung ihres Inhalts nicht gestattet, soweit nicht ausdrücklich zugestanden. Zuwiderhandlungen verpflichten zu Schadenersatz.

| | | | |
|----------------------|---|---|--|
| Bemerkung - Note | Technische Daten - technical data Weight = 7.375 [kg] Torque max. (M1/M2) = 50 / 25 [Nm] Speed max. (n1/n2) = 6000 / 12000 [1/min] Gear ratio (i)=n1:n2 = 2:1 | Benennung - Title Radial Bohr und Fräskopf Radial drilling and milling head |  EWS Weigle GmbH & Co. KG Maybachstr. 1 D-73066 Uhlingen www.ews-tools.de Technische Änderungen vorbehalten! Subject to technical modifications! IDENT: DEWS254969 Nr. - No. 60.5525BIG180911MX100#01 MNR. 230723  |
|----------------------|---|---|--|