

Spannzange / collet ER25 DIN6499  
Spannbereich / clamping range: 1,0 - 16,0

Gewindebohrzange / tapping collet  
ET-1-25 M3-M12

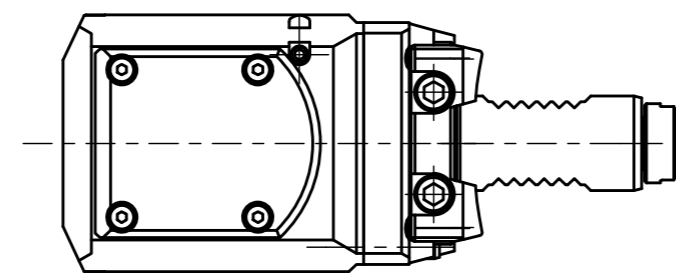

Doppelverzahnung Lizenz Traub  
double tooth system licence Traub

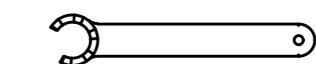
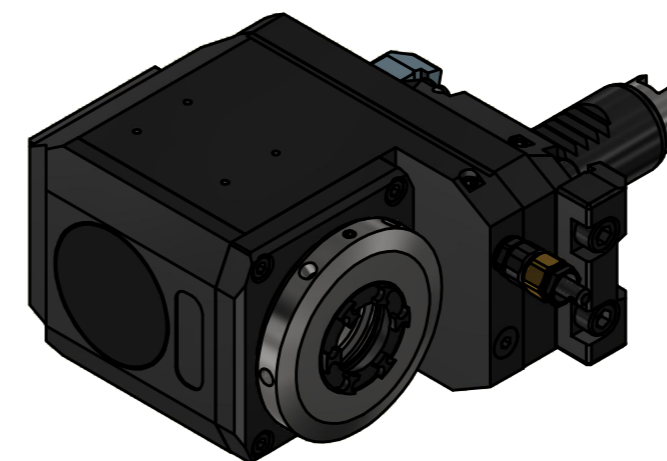

Spannzangenschlüssel für  
innenliegende Mutter  
Clamping wrench for  
internal collet  
225AX

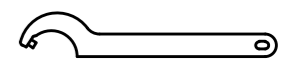

Hakenschlüssel  
mit Zapfen  
Hook wrench  
with fixed pin  
DIN1810 B 58x62

Copyright **EWS Tool Technologies**  
Weitergabe und Vervielfältigung dieser Unterlage,  
Verwertung und Mitteilung ihres Inhalts nicht  
gestattet, soweit nicht ausdrücklich zugestanden.  
Zuwerhandlungen verpflichten zu Schadenersatz.

Bemerkung - Note	Technische Daten - technical data Weight = 4.278 [kg] Torque max. (M1/M2) = 25 / 25 [Nm] Speed max. (n1/n2) = 8000 / 8000 [1/min] Gear ratio (i)=n1:n2 = 1:1	Benennung - Title <b>Radial Bohr und Fräskopf, zurückges</b> <b>Radial drill. and mill. head offset</b>	<table border="1"> <tr> <td data-bbox="2240 1915 2463 1984"> <b>EWS</b>  <small>EWS Weigle GmbH &amp; Co. KG            Maybachstr. 1            D-73066 Ulm/ingen            www.ews-tools.de</small> </td> <td data-bbox="2463 1915 2686 1984">           Technische Änderungen vorbehalten!            Subject to technical modifications!            IDENT: DEWS255278         </td> <td data-bbox="2686 1915 2923 1984">             REV: -/A            MNR.         </td> </tr> <tr> <td data-bbox="2240 1984 2463 2047">           Nr. - No.  <b>80.2525G200RLIM#01</b> </td> <td colspan="2" data-bbox="2463 1984 2923 2047"> <b>230813</b>  <div style="font-size: 2em; font-weight: bold; float: right;">QR</div> </td> </tr> </table>	<b>EWS</b> <small>EWS Weigle GmbH &amp; Co. KG            Maybachstr. 1            D-73066 Ulm/ingen            www.ews-tools.de</small>	Technische Änderungen vorbehalten! Subject to technical modifications! IDENT: DEWS255278	 REV: -/A MNR.	Nr. - No. <b>80.2525G200RLIM#01</b>	<b>230813</b> <div style="font-size: 2em; font-weight: bold; float: right;">QR</div>	
<b>EWS</b> <small>EWS Weigle GmbH &amp; Co. KG            Maybachstr. 1            D-73066 Ulm/ingen            www.ews-tools.de</small>	Technische Änderungen vorbehalten! Subject to technical modifications! IDENT: DEWS255278	 REV: -/A MNR.							
Nr. - No. <b>80.2525G200RLIM#01</b>	<b>230813</b> <div style="font-size: 2em; font-weight: bold; float: right;">QR</div>								