

W-Verzahnung Lizenz Index-Werke  
W-tooth system licence Index-Corporation

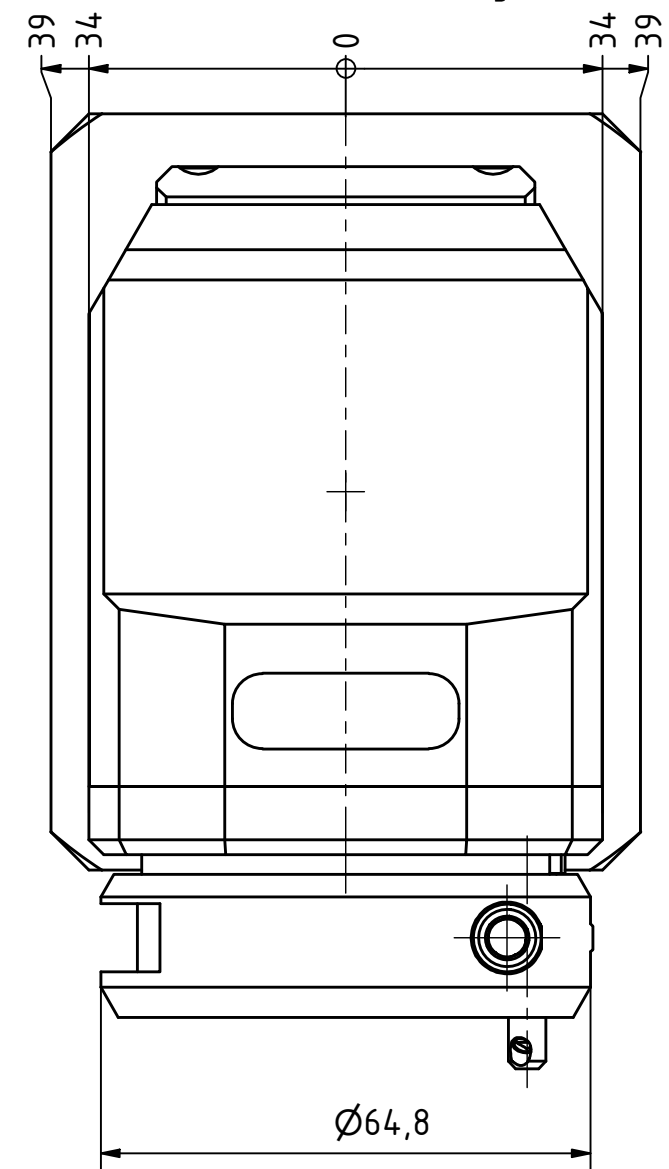

Anlagefläche  
contact surface

EWS-Varia VX3

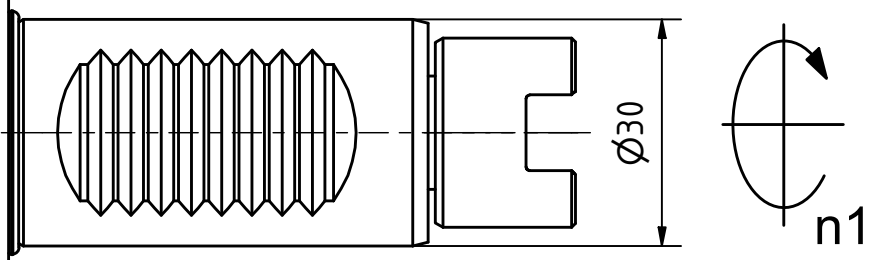
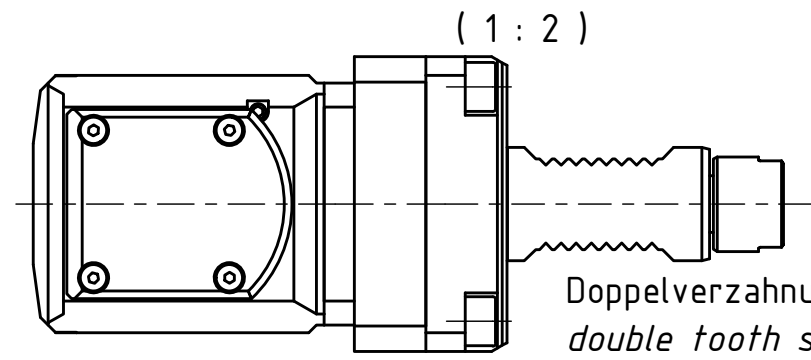
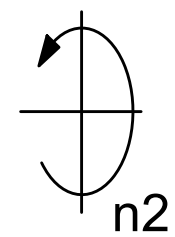

Doppelverzahnung Lizenz Traub  
double tooth system licence Traub

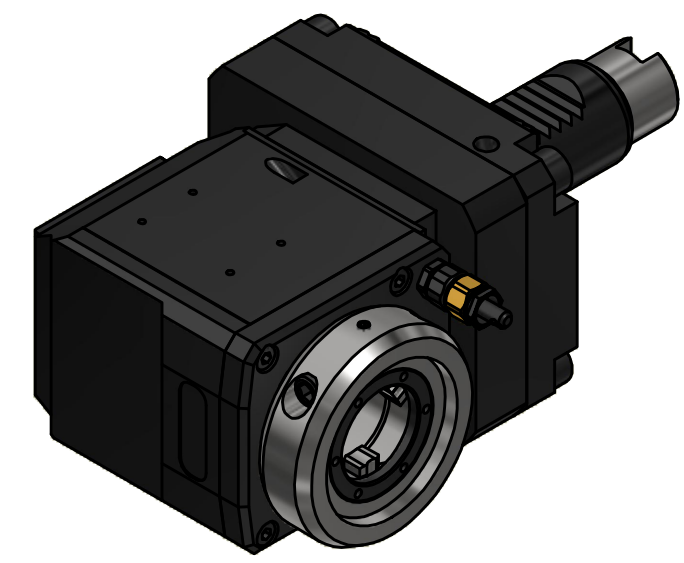

Copyright **EWS Tool Technologies**  
Weitergabe und Vervielfaeltigung dieser Unterlage,  
Verwertung und Mitteilung ihres Inhalts nicht  
gestattet, soweit nicht ausdrecklich zugestanden.  
Zuwiderhandlungen verpflichten zu Schadenersatz.

Bemerkung - Note  
mit Kegelrollenlager  
with taper roller bearing(s)

Technische Daten - technical data  
Weight = 5.557 [kg]  
Torque max. (M1/M2) = 20 / 40 [Nm]  
Speed max. (n1/n2) = 8000 / 4000 [1/min]  
Gear ratio (i)=n1:n2 = 2:1

Benennung - Title  
**Radial Bohr und Fräskopf**  
**Radial drilling and milling head**

**EWS** Tool Technologies  
EWS Weigele GmbH & Co. KG  
Maybachstr. 1  
D-73066 UHINGEN  
www.ews-tools.de

Technische Aenderungen vorbehalten!  
Subject to technical modifications!  
IDENT: DEWS255384  
REV: -/A  
MNR.  
230829

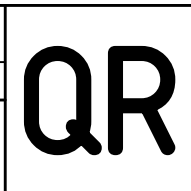

Nr. - No.  
**60.30VX3KRG300RLI2W#01**