

Spannzange / collet ER32 DIN6499
Spannbereich / clamping range: 2,0 - 20,0

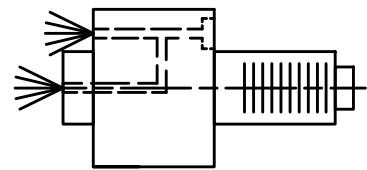

Innen- und Aussenkuehlung / Inside and outside coolant supply
Kuehlmittelfiltrierung<math>< 50\mu</math> / coolant filtration<math>< 50\mu</math>

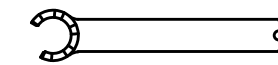
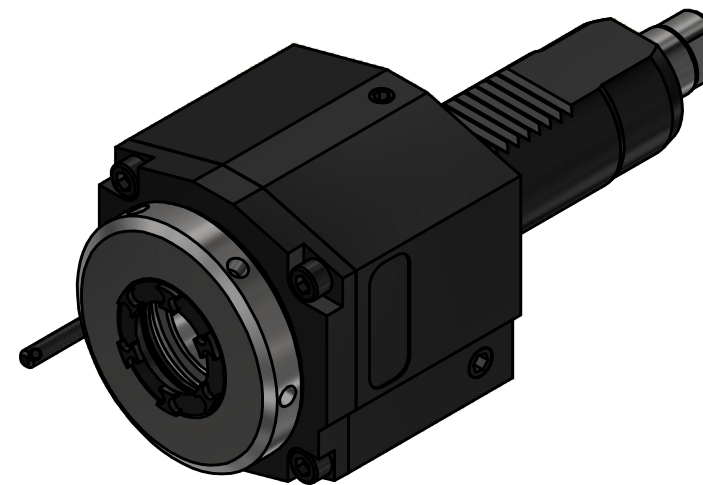

Spannzangenschlüssel für innenliegende Mutter
Clamping wrench for internal collet
232AX

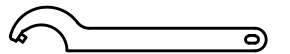

Hakenschlüssel mit Zapfen
Hook wrench with fixed pin
DIN1810 B 68x75

Copyright **EWS Tool Technologies**
Weitergabe und Vervielfaeltigung dieser Unterlage, Verwertung und Mitteilung ihres Inhalts nicht gestattet, soweit nicht ausdrecklich zugestanden. Zuwiderhandlungen verpflichten zu Schadenersatz.

Bemerkung - Note
Für Trockenlauf geeignet!
Use without coolant fluid allowed!

Technische Daten - technical data
Weight = 4.339 [kg]
Torque max. (M1/M2) = 63 / 63 [Nm]
Speed max. (n1/n2) = 12000 / 12000 [1/min]
Gear ratio (i)=n1:n2 = 1:1
Pressure (pmax) = 70 [bar]

Benennung - Title
Axial Bohr und Fräskopf
Axial drilling and milling head



Nr. - No.
40.4032LVL3IKCIMHSD12

Technische Aenderungen vorbehalten!
Subject to technical modifications!
IDENT: DEWS255037

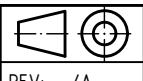

REV: -/A
MNR.
230791



30.08.2000