

Doppelverzahnung Lizenz Traub
double tooth system licence Traub

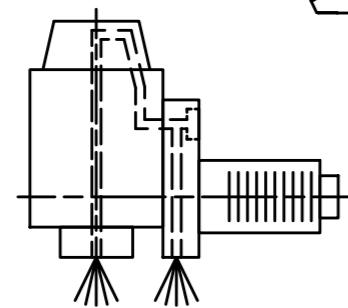

Innen- und Aussenkuehlung / Inside and outside coolant supply
Kuehlmittelfiltrierung+50 μ / coolant filtration+50 μ

Benennung - Title	Technische Daten - technical data
Für Trockenlauf geeignet! Use without coolant fluid allowed!	Weight = 5.413 [kg] Torque max. (M1/M2) = 32 / 32 [Nm] Speed max. (n1/n2) = 8000 / 8000 [1/min] Gear ratio (i)=n1:n2 = 1:1 Pressure (pmax) = 70 [bar]

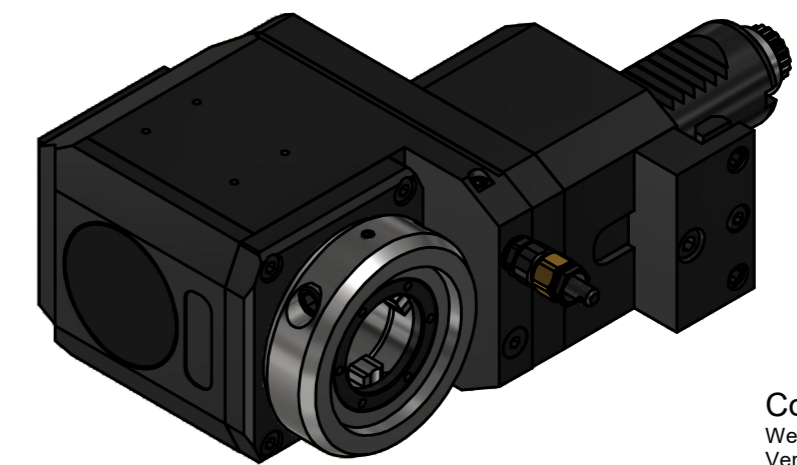

Copyright **EWS Tool Technologies**
Weitergabe und Vervielfaeltigung dieser Unterlage,
Verwertung und Mitteilung ihres Inhalts nicht
gestattet, soweit nicht ausdrecklich zugestanden.
Zuwoerhandlungen verpflichten zu Schadenersatz.

EWS Tool Technologies		EWS Weigela GmbH & Co. KG Maybachstr. 1 D-73066 Uhlingen www.ews-tool.de		Technische Aenderungen vorbehalten! Subject to technical modifications!	
Nr. - No.	80.30VX3E365RLIKDA35	IDENT: DEWS254469	REV: -/A	MNR.	230619

