

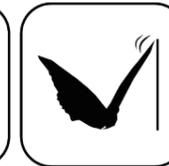

Ceramic Seal

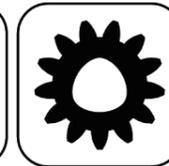

Butterfly Seal



Polygon Joint

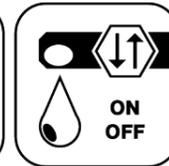

Coolant Management



Tech Details

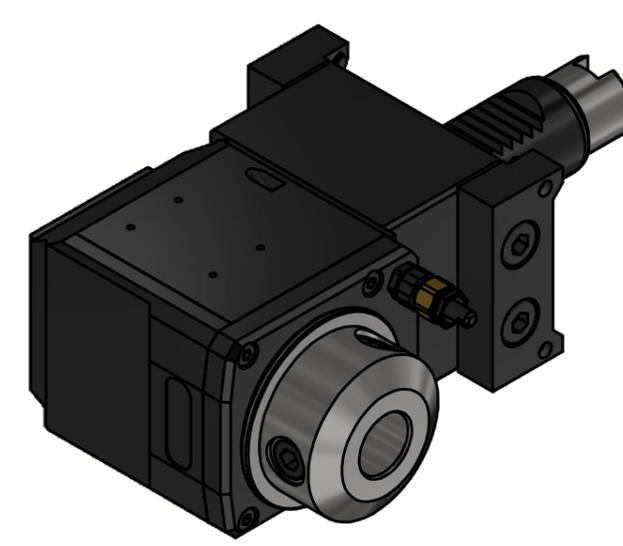
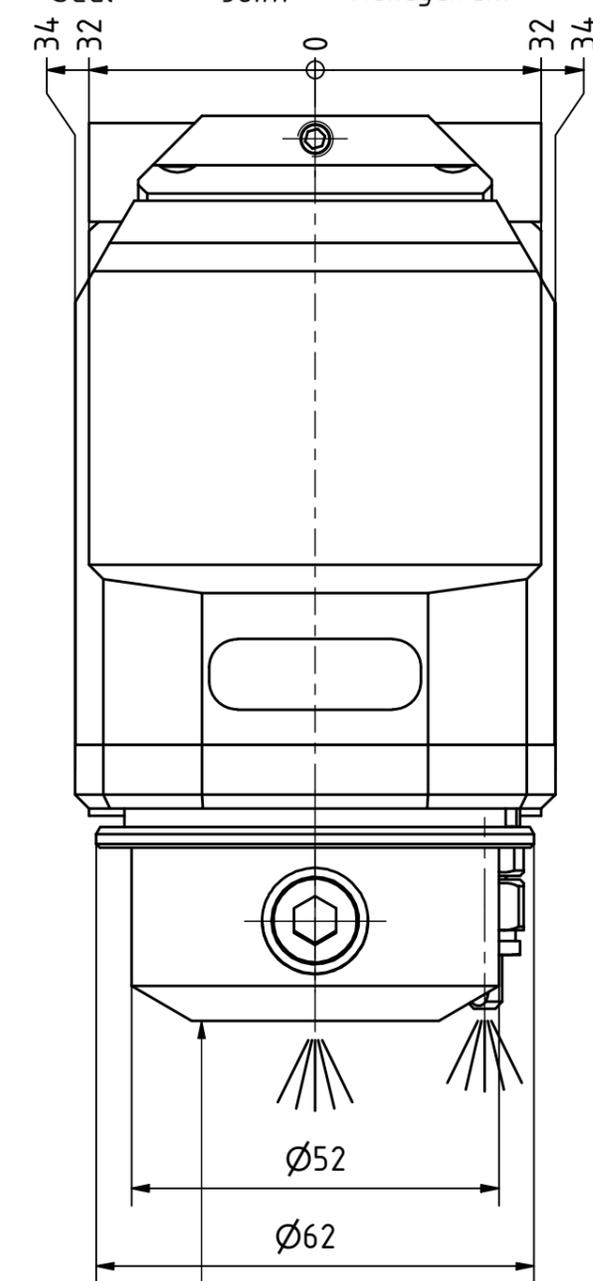
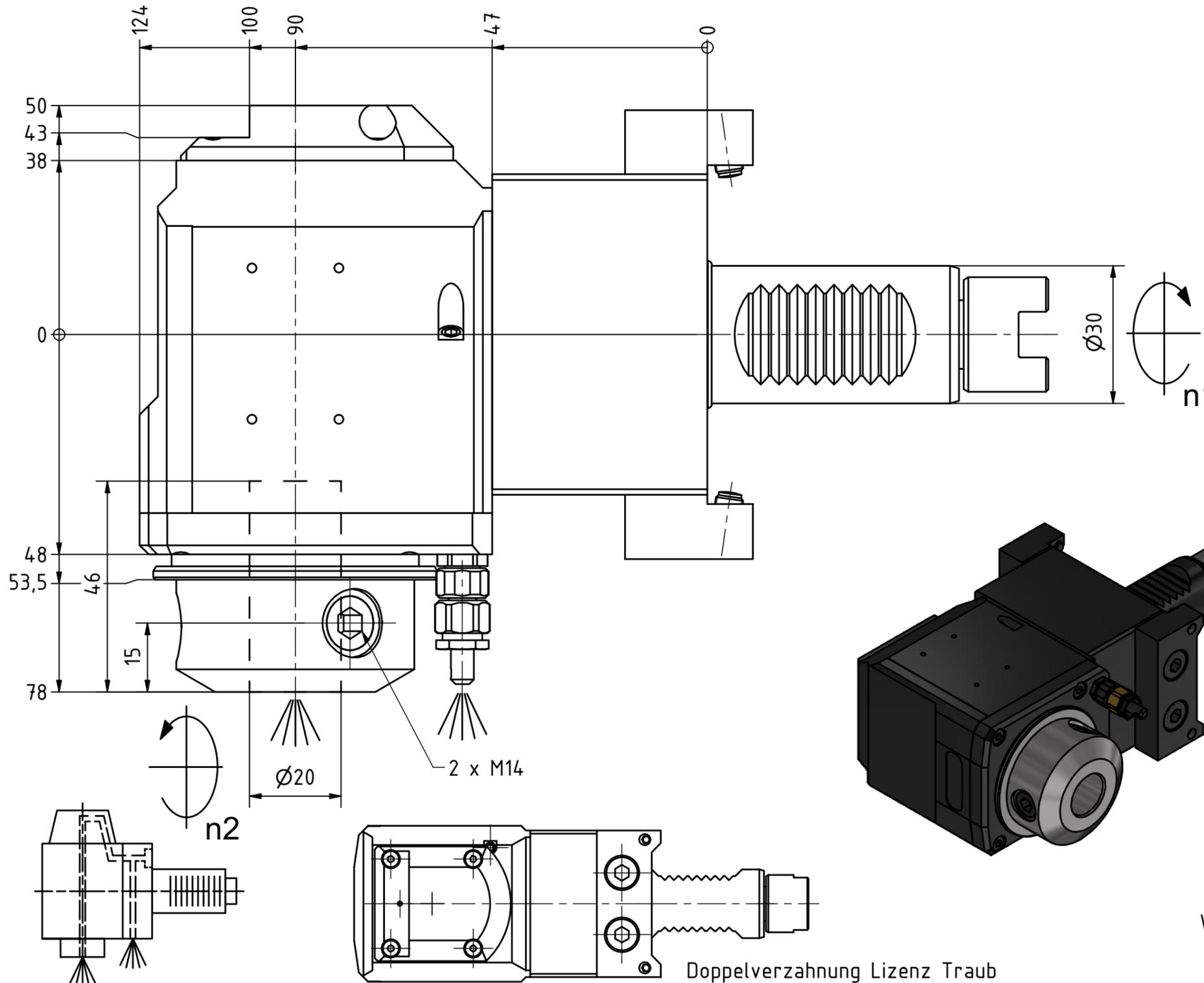

Whistle Notch / Weldon

Copyright **EWS Tool Technologies**  
 Weitergabe und Vervielfaeltigung dieser Unterlage,  
 Verwertung und Mitteilung ihres Inhalts nicht  
 gestattet, soweit nicht ausdrucklich zugestanden.  
 Zuwiderhandlungen verpflichten zu Schadenersatz.

Bemerkung - Note  
 Für Trockenlauf geeignet!  
 Use without coolant fluid allowed!  
 mit Kegelrollenlager  
 with taper roller bearing(s)

Technische Daten - technical data	
Weight	= 5.054 [kg]
Torque max. (M1/M2)	= 20 / 40 [Nm]
Speed max. (n1/n2)	= 8000 / 4000 [1/min]
Gear ratio (i)=n1:n2	= 2:1
Pressure (pmax)	= 70 [bar]

Benennung - Title  
**Radial Bohr und Fräskopf**  
**Radial drilling and milling head**



Nr. - No.  
**60.3020WNRKRTNX65RLIKDI2**

Technische Aenderungen vorbehalten!  
 Subject to technical modifications!  
 IDENT: DEWS253429



REV: -/A

MNR.

**230450**

