

Hakenschlüssel  
mit Nase  
Hook wrench with  
nose end  
DIN1810 A 58x62

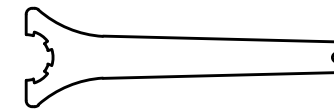

Spannzangenschlüssel  
Clamping wrench  
225



Highspeed



Tech  
Details

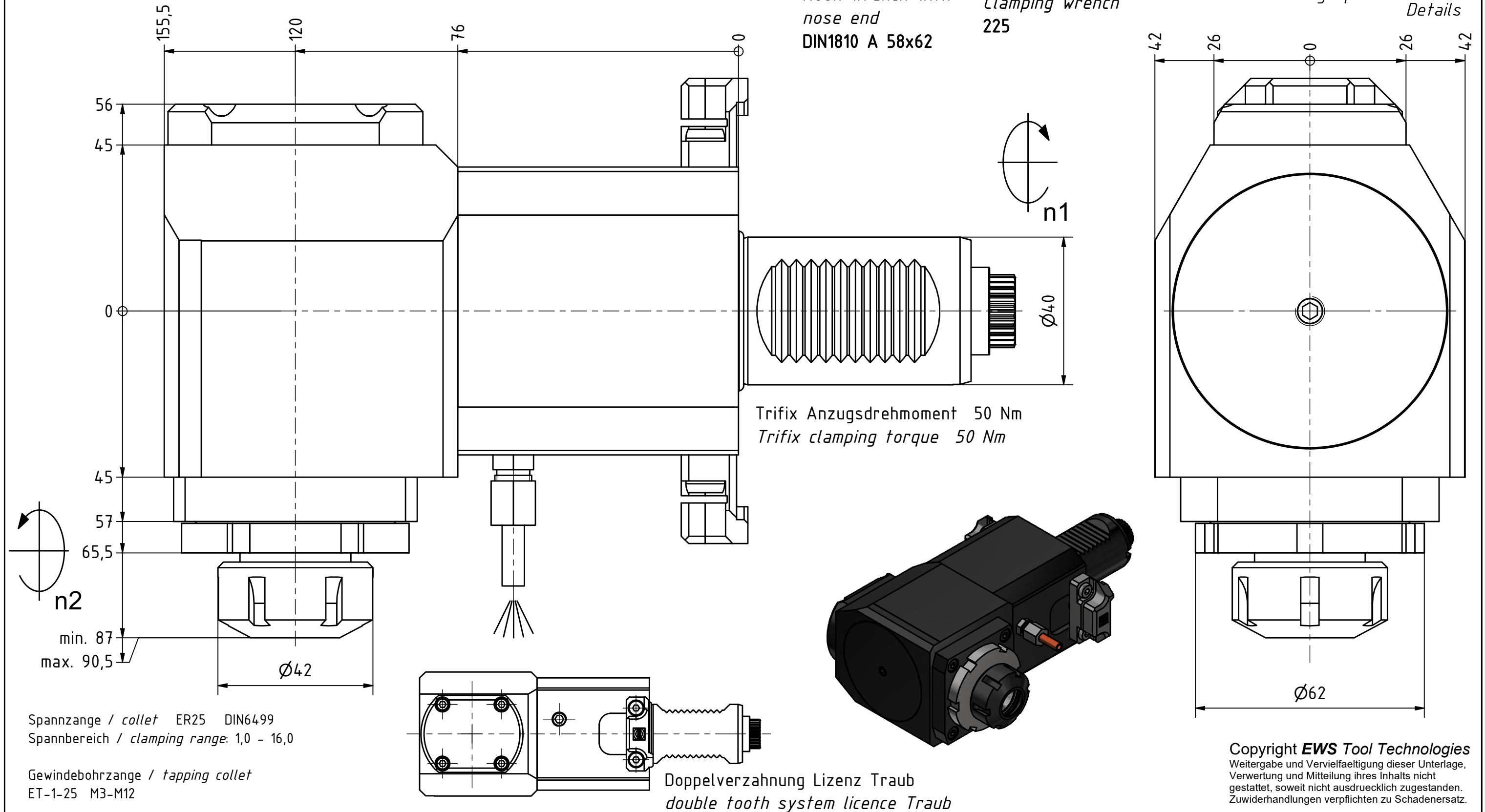

Spannzange / collet ER25 DIN6499  
Spannbereich / clamping range: 1,0 - 16,0

Gewindebohrzange / tapping collet  
ET-1-25 M3-M12

Doppelverzahnung Lizenz Traub  
double tooth system licence Traub

Copyright **EWS Tool Technologies**  
Weitergabe und Vervielfältigung dieser Unterlage,  
Verwertung und Mitteilung ihres Inhalts nicht  
gestattet, soweit nicht ausdrücklich zugestanden.  
Zuwendungen verpflichten zu Schadenersatz.

Bemerkung - Note

Technische Daten - technical data  
Weight = 7.521 [kg]  
Torque max. (M1/M2) = 45 / 15 [Nm]  
Speed max. (n1/n2) = 5000 / 15000 [1/min]  
Gear ratio (i)=n1:n2 = 1:3

Benennung - Title  
**Radial Bohr und Fräskopf**  
**Radial drilling and milling head**

**EWS** Tool Technologies  
EWS Weigle GmbH & Co. KG  
Maybachstr. 1  
D-73066 Uthingen  
www.ews-tools.de

Technische Änderungen vorbehalten!  
Subject to technical modifications!  
IDENT: DEWS252652  
REV: -/A  
MNR.  
230364

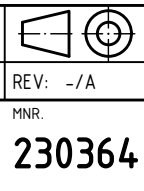

Nr. - No.  
**60.4025LCTXRLI13TFR**