

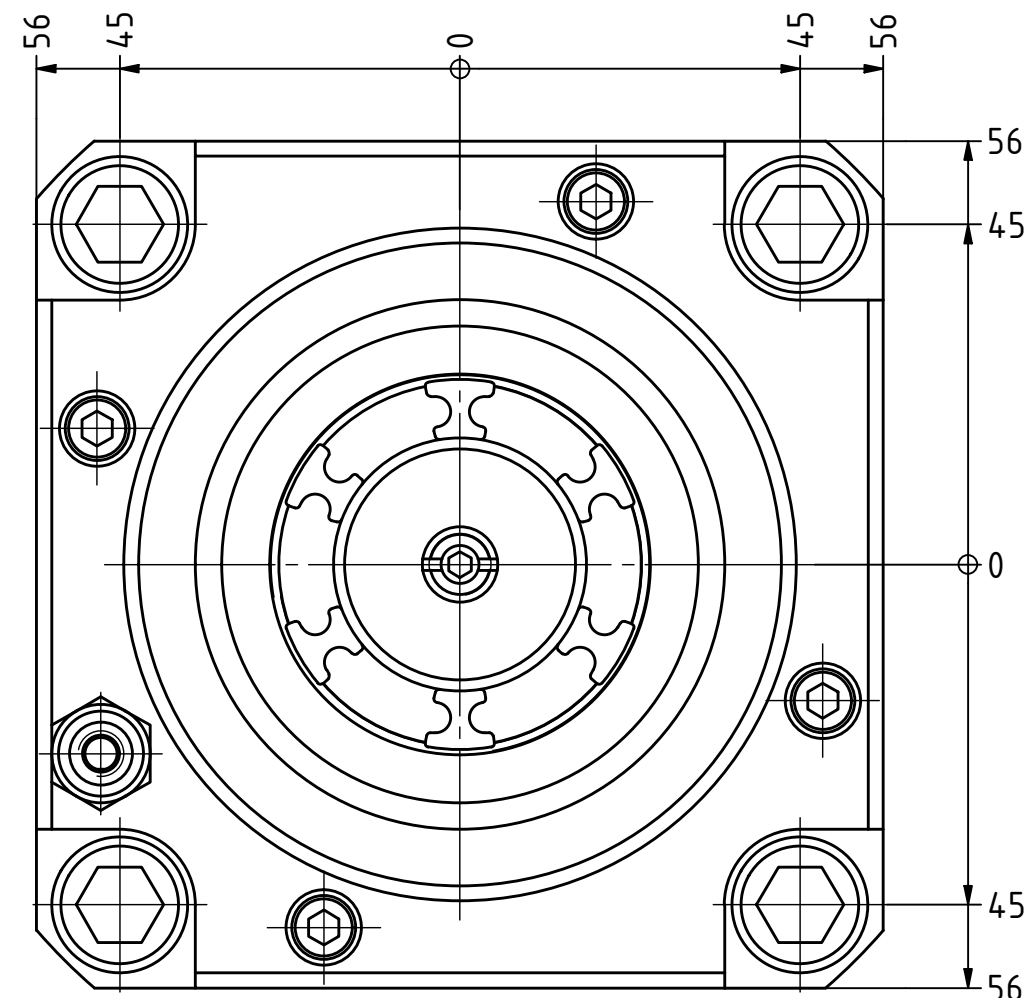

Ceramic Seal

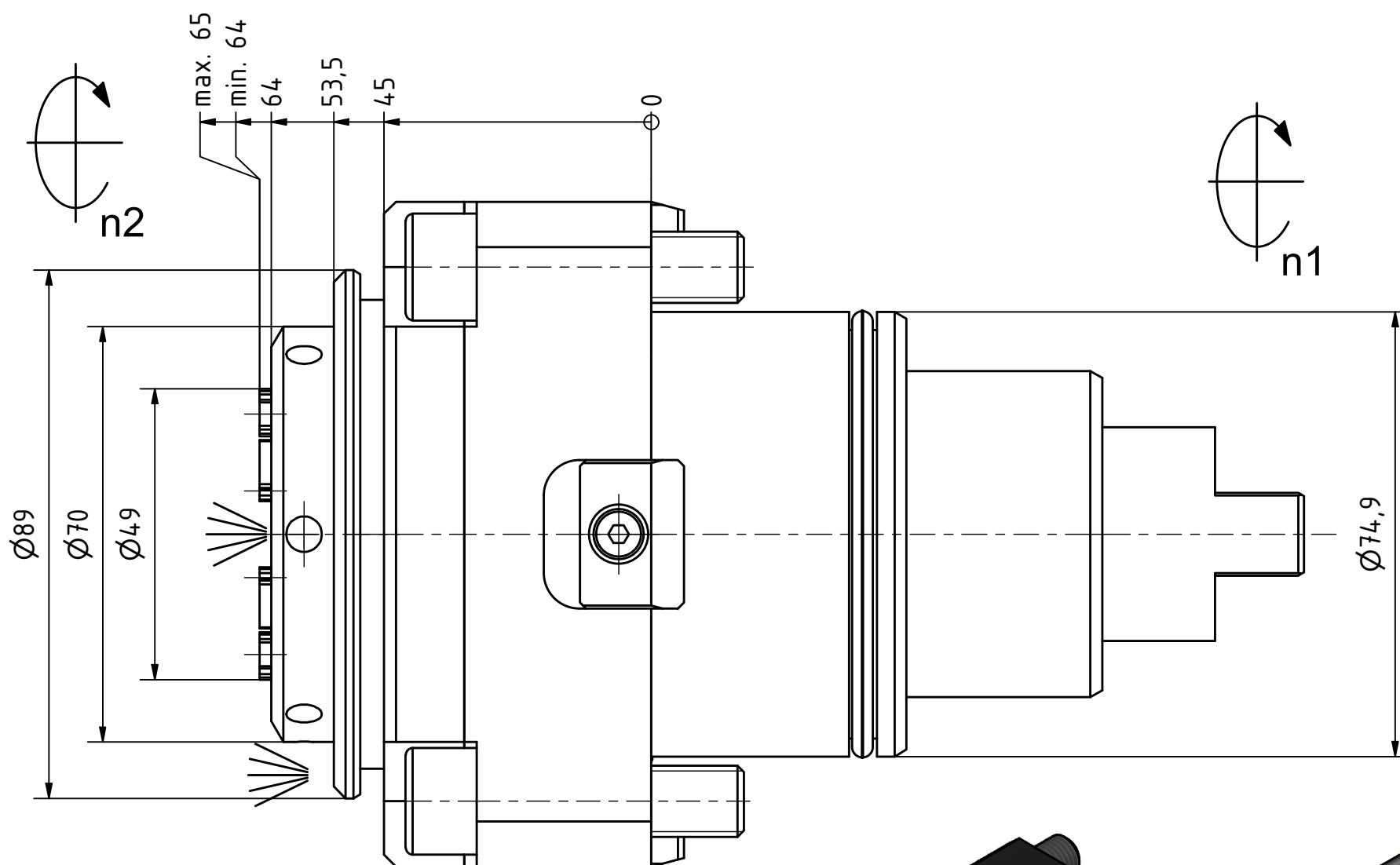

Tech Details



Spannzange / collet ER40 DIN6499  
 Spannbereich / clamping range: 3,0 - 26,0

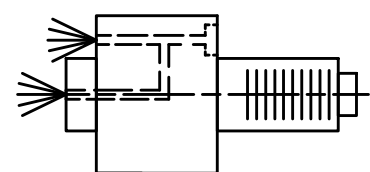
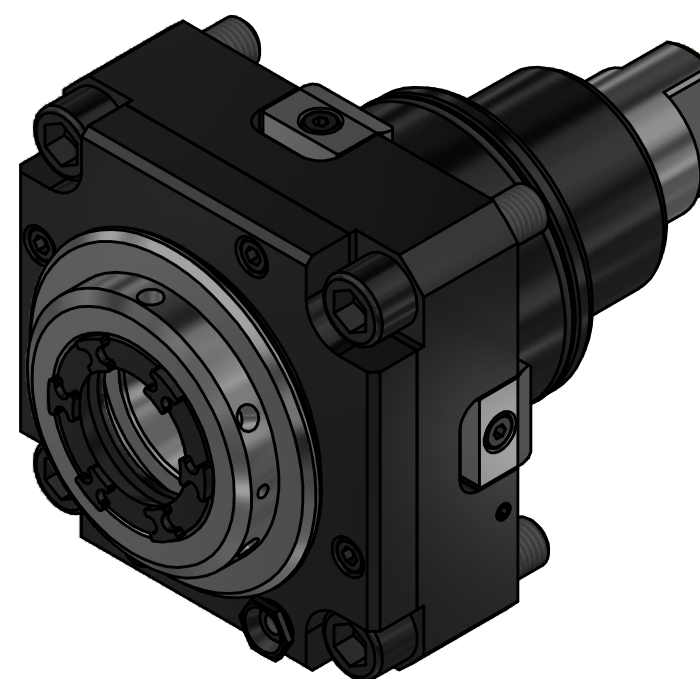

Innen- und Aussenkuehlung / Inside and outside coolant supply  
 Kuehlmittelfiltrierung <50µ / coolant filtration <50µ

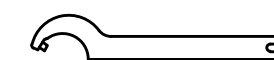

Hakenschlüssel  
 mit Zapfen  
 Hook wrench  
 with fixed pin  
 DIN1810 B 68x75

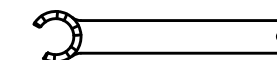

Spannzangenschlüssel für  
 innenliegende Mutter  
 Clamping wrench for  
 internal collet  
 240AX

Copyright **EWS Tool Technologies**

Weitergabe und Vervielfaeltigung dieser Unterlage,  
 Verwertung und Mitteilung ihres Inhalts nicht  
 gestattet, soweit nicht ausdrecklich zugestanden.  
 Zuwiderhandlungen verpflichten zu Schadenersatz.

Bemerkung - Note

Für Trockenlauf geeignet!  
 Use without coolant fluid allowed!

Technische Daten - technical data

Weight = 5.971 [kg]  
 Torque max. (M1/M2) = 100 / 100 [Nm]  
 Speed max. (n1/n2) = 6000 / 6000 [1/min]  
 Gear ratio (i)=n1:n2 = 1:1  
 Pressure (pmax) = 70 [bar]

Benennung - Title

**Axial Bohr und Fräskopf**  
**Axial drilling and milling head**



Nr. - No.  
**40.75401809IKDIM**

Technische Aenderungen vorbehalten!  
 Subject to technical modifications!

IDENT: DEWS252048



REV: -/A

MNR.  
**230294**

