

Spannzange / collet ER25 DIN6499  
 Spannbereich / clamping range: 1,0 - 16,0

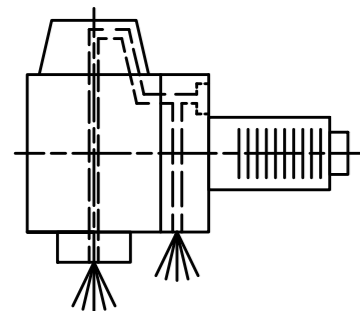

Innen- und Aussenkuehlung / Inside and outside coolant supply  
 Kein Trockenlauf / No dry run  
 Kuehlmittefiltrierung-50µ / coolant filtration-50µ

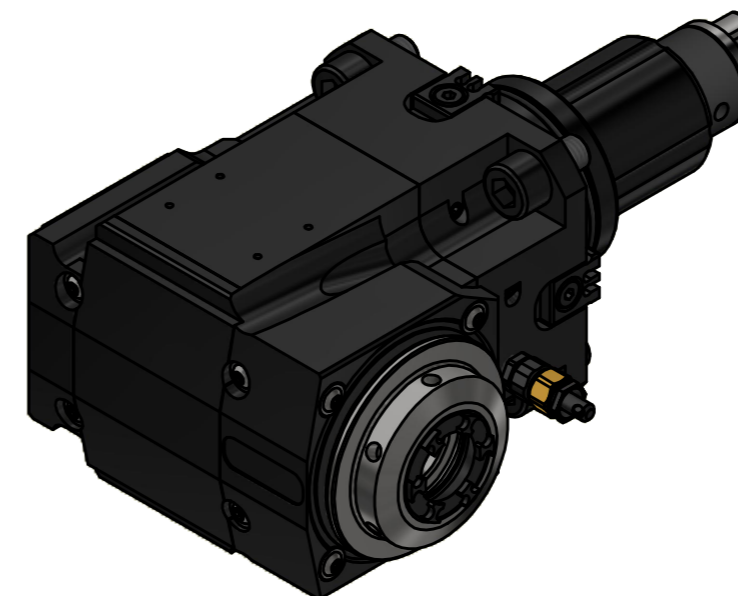
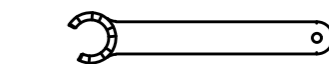

Spannzangenschlüssel für innenliegende Mutter  
 Clamping wrench for internal collet  
 225AX

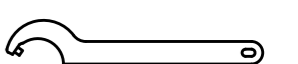

Hakenschlüssel mit Zapfen  
 Hook wrench with fixed pin  
 DIN1810 B 45x50

Copyright **EWS Tool Technologies**  
 Weitergabe und Vervielfaeltigung dieser Unterlage, Verwertung und Mitteilung ihres Inhalts nicht gestattet, soweit nicht ausdrecklich zugestanden. Zuwiderhandlungen verpflichten zu Schadenersatz.

Benennung - Title	Technische Daten - technical data
Für Trockenlauf geeignet! Use without coolant fluid allowed!	Weight = 7.413 [kg]
mit Kegelrollenlager with taper roller bearing(s)	Torque max. (M1/M2) = 40 / 80 [Nm]
	Speed max. (n1/n2) = 6000 / 3000 [1/min]
	Gear ratio (i)=n1:n2 = 2:1
	Pressure (pmax) = 70 [bar]

Benennung - Title  
**Radial Bohr und Fräskopf**  
**Radial drilling and milling head**

 EWS Weigle GmbH & Co. KG Maybachstr. 1 D-73066 Uhlingen www.ews-tools.de	Technische Aenderungen vorbehalten! Subject to technical modifications! IDENT: DEWS251972	REV: -/A MNR.
	Nr. - No. <b>60.5525KR1809PFIKDGLI2IMX85</b>	<b>230220</b>

