

Spannzange / collet ER25 DIN6499  
Spannbereich / clamping range: 1,0 - 16,0

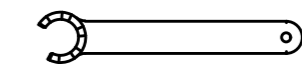

Spannzangenschlüssel für  
innenliegende Mutter  
Clamping wrench for  
internal collet  
225AX

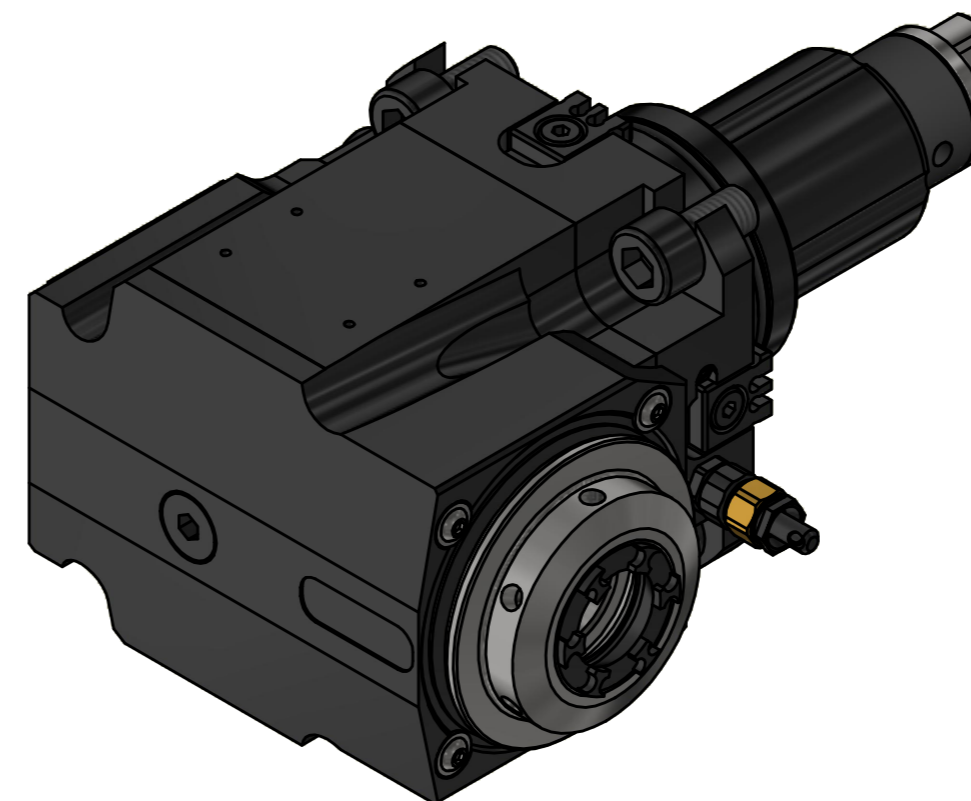
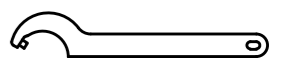

Hakenschlüssel  
mit Zapfen  
Hook wrench  
with fixed pin  
DIN1810 B 45x50

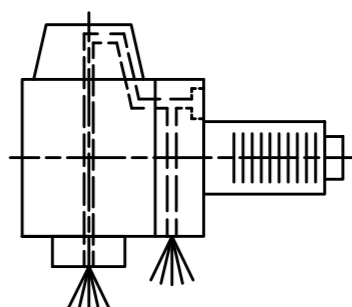

Innen- und Aussenkuehlung / Inside and outside coolant supply  
Kuehlmittelfiltrierung=50µ / coolant filtration=50µ

Bemerkung - Note  
Für Trockenlauf geeignet!  
Use without coolant fluid allowed!

Technische Daten - technical data  
Weight = 7.153 [kg]  
Torque max. (M1/M2) = 63 / 63 [Nm]  
Speed max. (n1/n2) = 6000 / 6000 [1/min]  
Gear ratio (i)=n1:n2 = 1:1  
Pressure (pmax) = 70 [bar]

Benennung - Title  
Radial Bohr und Fräskopf  
Radial drilling and milling head

	<small>EWS Weigle GmbH &amp; Co. KG Maybachstr. 1 D-73066 Uhingen www.ews-tool.de</small>	<small>Technische Änderungen vorbehalten! Subject to technical modifications!</small>	
	<small>Nr. - No.</small> 60.55251809PFIKDGLIMX70	<small>IDENT: DEWS251669</small>	

Copyright EWS Tool Technologies  
Weitergabe und Vervielfältigung dieser Unterlage,  
Verwertung und Mitteilung ihres Inhalts nicht  
gestattet, soweit nicht ausdrücklich zugestanden.  
Zuwerhandlungen verpflichten zu Schadenersatz.