

Spannzange / collet ER25 DIN6499
 Spannbereich / clamping range: 1,0 - 16,0

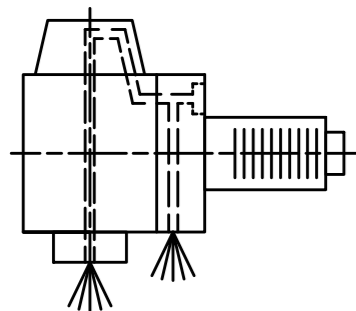
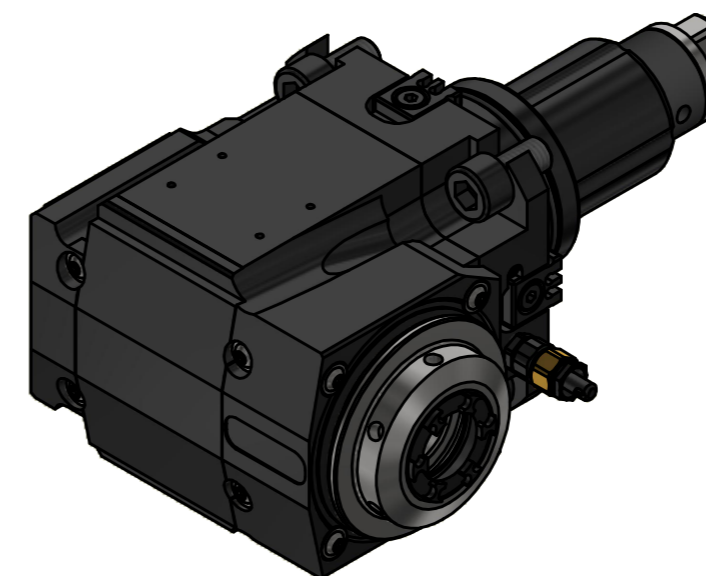

Innen- und Aussenkuehlung / Inside and outside coolant supply
 Kein Trockenlauf / No dry run
 Kuehlmittefiltrierung-50µ / coolant filtration-50µ

Spannzangenschlüssel für innenliegende Mutter
 Clamping wrench for internal collet
 225AX

Hakenschlüssel mit Zapfen
 Hook wrench with fixed pin
 DIN1810 B 45x50

Copyright EWS Tool Technologies
 Weitergabe und Vervielfaeltigung dieser Unterlage,
 Verwertung und Mitteilung ihres Inhalts nicht
 gestattet, soweit nicht ausdrecklich zugestanden.
 Zuwiderhandlungen verpflichten zu Schadenersatz.

<p>Bemerkung - Note Für Trockenlauf geeignet! Use without coolant fluid allowed! mit Kegelrollenlager with taper roller bearing(s)</p>	<p>Technische Daten - technical data Weight = 6.724 [kg] Torque max. (M1/M2) = 40 / 80 [Nm] Speed max. (n1/n2) = 6000 / 3000 [1/min] Gear ratio (i)=n1:n2 = 2:1 Pressure (pmax) = 70 [bar]</p>	<p>Benennung - Title Radial Bohr und Fräskopf Radial drilling and milling head</p>	<p>EWS Tool Technologies EWS Weigle GmbH & Co. KG Maybachstr. 1 D-73066 Uhlingen www.ews-tool.de</p> <p>Technische Aenderungen vorbehalten! Subject to technical modifications! IDENT: DEWS251756 Nr. - No. 60.5525KR1809PFIKDGLI2IMX70 MNR. REV: -/A 230200</p> <p>QR</p>
--	---	--	--