

Spannzange / collet ER25 DIN6499
 Spannbereich / clamping range: 1,0 - 16,0

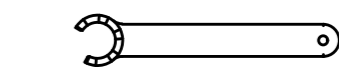

Spannzangenschlüssel für
 innenliegende Mutter
 Clamping wrench for
 internal collet
 225AX

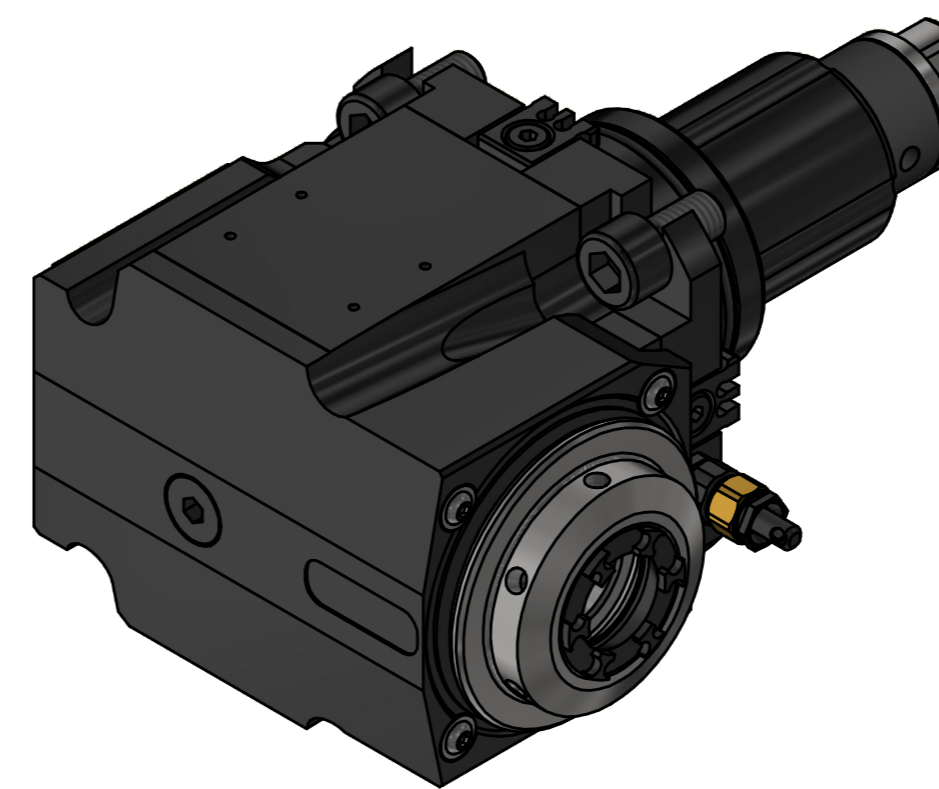

Hakenschlüssel
 mit Zapfen
 Hook wrench
 with fixed pin
 DIN1810 B 45x50

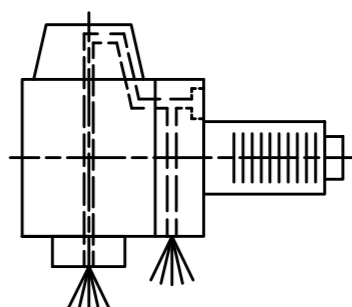

Innen- und Aussenkühlung / Inside and outside coolant supply
 Kühlmittelfiltrierung=50µ / coolant filtration=50µ

Copyright **EWS Tool Technologies**
 Weitergabe und Vervielfältigung dieser Unterlage,
 Verwertung und Mitteilung ihres Inhalts nicht
 gestattet, soweit nicht ausdrücklich zugestanden.
 Zuwiderhandlungen verpflichten zu Schadenersatz.

Bemerkung - Note	Technische Daten - technical data
Für Trockenlauf geeignet! Use without coolant fluid allowed!	Weight = 6.629 [kg] Torque max. (M1/M2) = 50 / 25 [Nm] Speed max. (n1/n2) = 6000 / 12000 [1/min] Gear ratio (i)=n1:n2 = 1:2 Pressure (pmax) = 70 [bar]

Benennung - Title
Radial Bohr und Fräskopf Radial drilling and milling head

EWS Tool Technologies EWS Weigle GmbH & Co. KG Maybachstr. 1 D-73066 Uhingen www.ews-tool.de	Technische Änderungen vorbehalten! Subject to technical modifications! IDENT: DEWS251512	REV: -/A MNR.	QR
---	--	------------------	-----------