

Fluchtungsfehlerausgleichend  
misalignment compensating

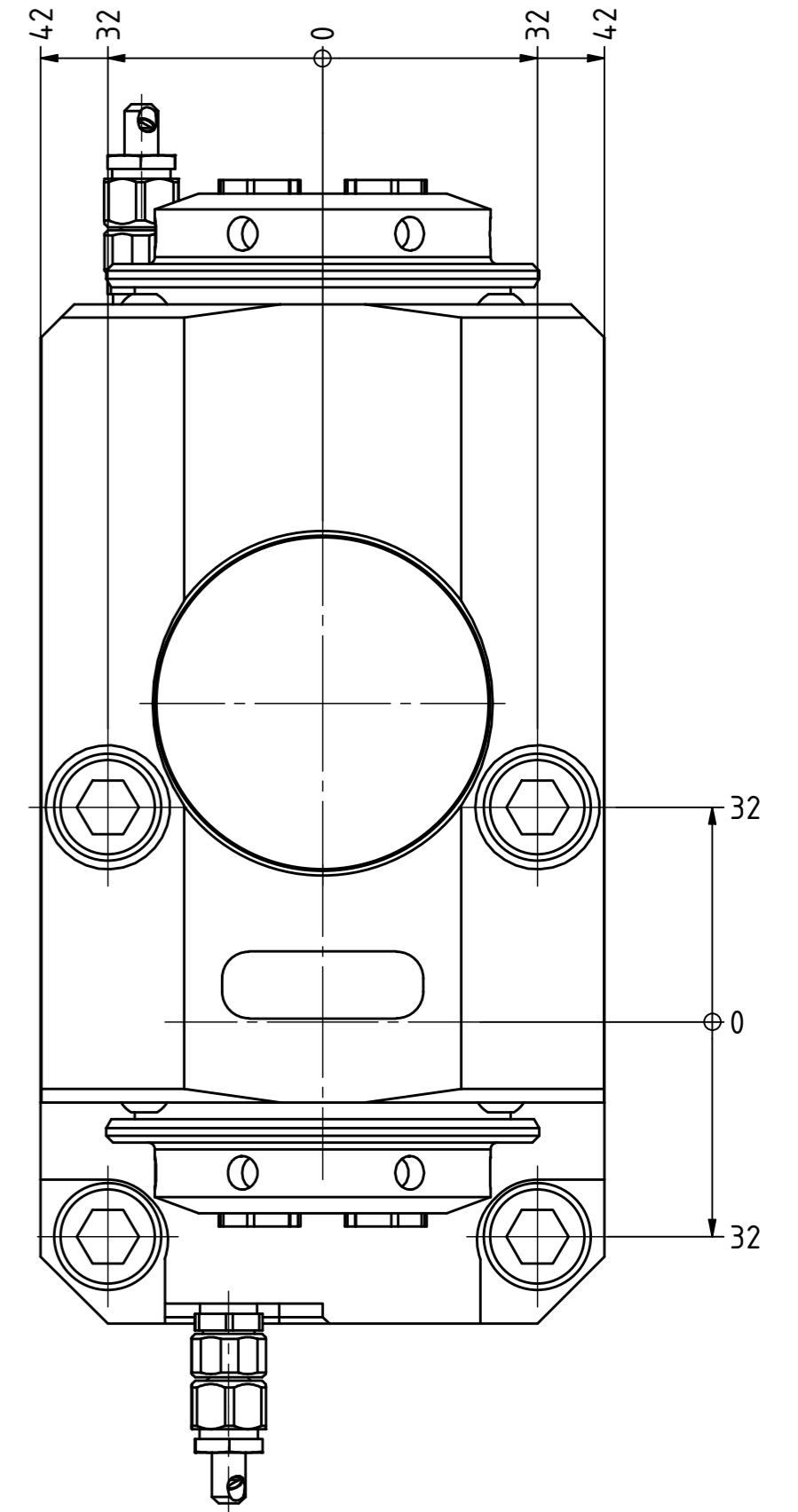

Spannzange / collet ER25 DIN6499  
Spannbereich / clamping range: 1,0 - 16,0

Gewindebohrzange / tapping collet  
ET-1-25 M3-M12

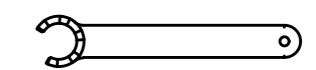
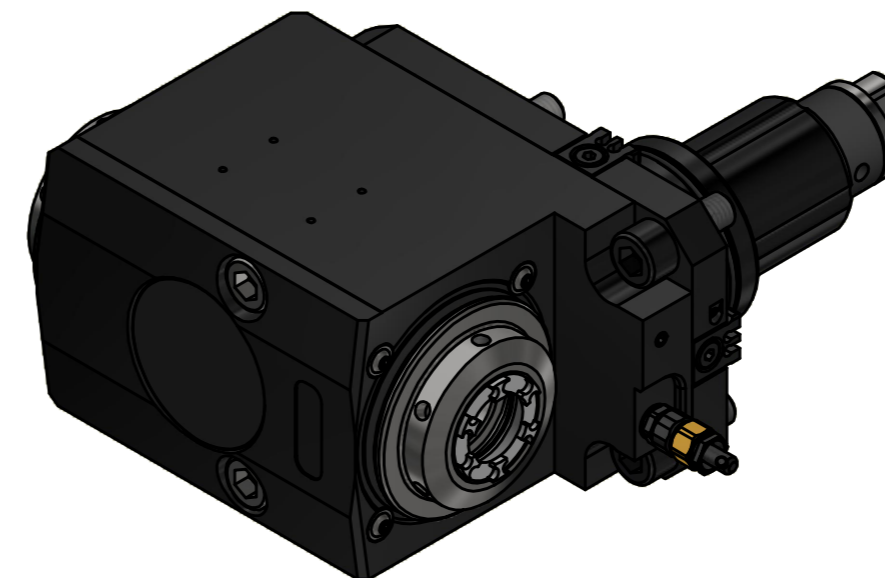

Spannzangenschlüssel für  
innenliegende Mutter  
Clamping wrench for  
internal collet  
225AX

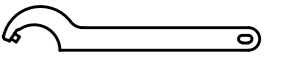

Hakenschlüssel  
mit Zapfen  
Hook wrench  
with fixed pin  
DIN1810 B 45x50  
225AX

Copyright EWS Tool Technologies  
Weitergabe und Vervielfältigung dieser Unterlage,  
Verwertung und Mitteilung ihres Inhalts nicht  
gestattet, soweit nicht ausdrücklich zugestanden.  
Zuwerhandlungen verpflichten zu Schadenersatz.

<p>Benennung - Title</p> <p>Radial Bohr und Fräskopf, zurückges Radial drill. and mill. head offset</p>	<p>Technische Daten - technical data</p> <p>Weight = 9,224 [kg]</p> <p>Torque max. (M1/M2) = 63 / 63   63 [Nm]</p> <p>Speed max. (n1/n2) = 6000 / 6000   6000 [1/min]</p> <p>Gear ratio (i)=n1:n2 = 1:1</p>	<p>Benennung - Title</p> <p>Radial Bohr und Fräskopf, zurückges Radial drill. and mill. head offset</p>	<p><b>EWS</b> Tool Technologies EWS Weigle GmbH &amp; Co. KG Maybachstr. 1 D-73066 Ulm/ingen www.ews-tool.de</p>	<p>Technische Änderungen vorbehalten! Subject to technical modifications!</p> <p>IDENT: DEWS252516</p> <p>REV: -/A</p> <p>MNR.</p> <p>230155</p>	<p>QR</p>
---	---	---	--	--	-----------