

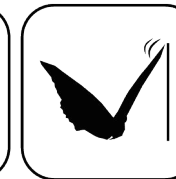

Ceramic Seal

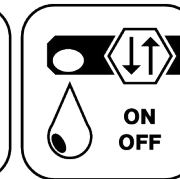

Butterfly Seal



Coolant Management



Tech Details

Fluchtungsfehlerausgleichend
misalignment compensating

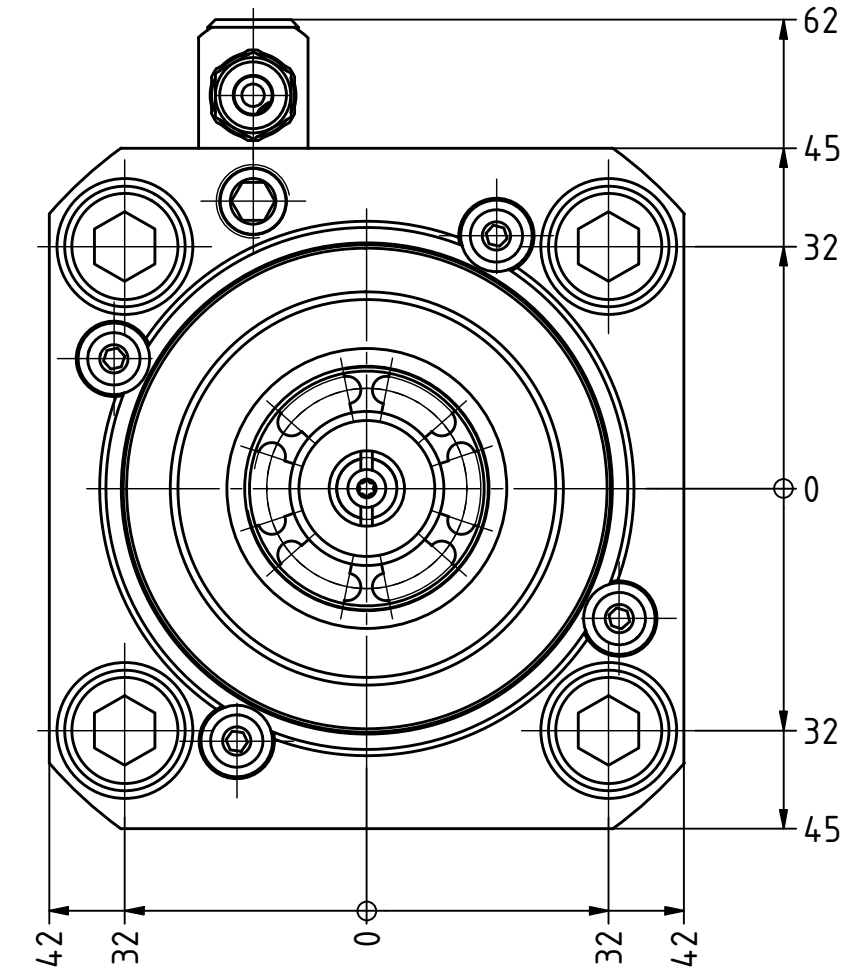
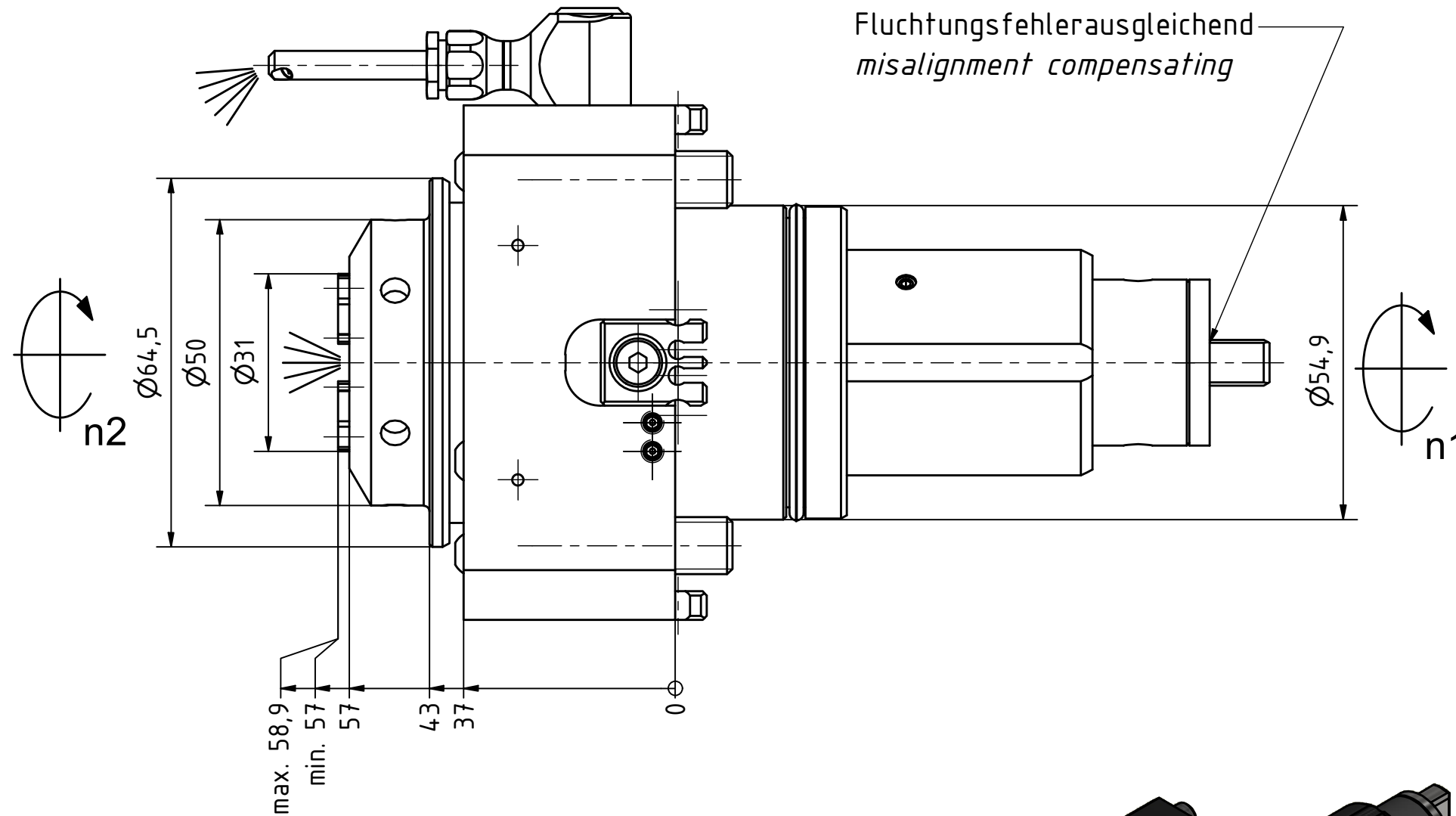

Spannzange / collet ER25 DIN6499
Spannbereich / clamping range: 1,0 - 16,0

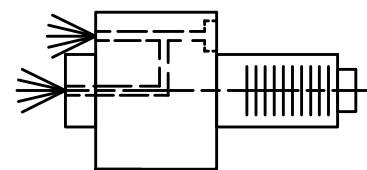

Innen- und Aussenkühlung / Inside and outside coolant supply
Kühlmittelfiltrierung <math>< 50\mu</math> / coolant filtration <math>< 50\mu</math>

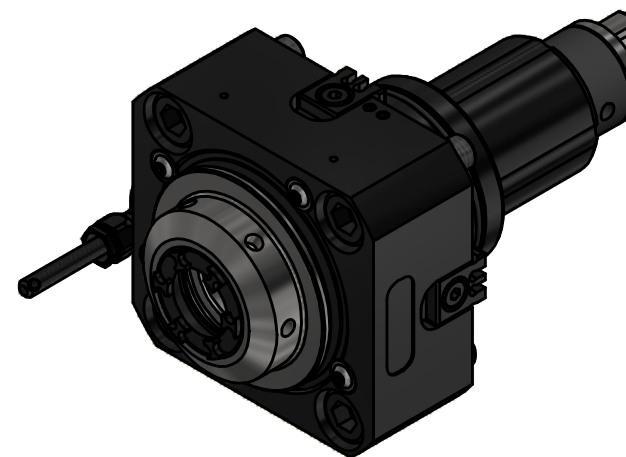

Hakenschlüssel
mit Zapfen
Hook wrench
with fixed pin
DIN1810 B 45x50

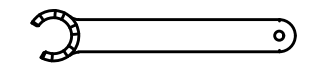

Spannzangenschlüssel für
innenliegende Mutter
Clamping wrench for
internal collet
225AX

Copyright **EWS Tool Technologies**
Weitergabe und Vervielfältigung dieser Unterlage,
Verwertung und Mitteilung ihres Inhalts nicht
gestattet, soweit nicht ausdrücklich zugestanden.
Zuwiderhandlungen verpflichten zu Schadenersatz.

Bemerkung - Note
Für Trockenlauf geeignet!
Use without coolant fluid allowed!

Technische Daten - technical data
Weight = 3,997 [kg]
Torque max. (M1/M2) = 63 / 63 [Nm]
Speed max. (n1/n2) = 6000 / 6000 [1/min]
Gear ratio (i)=n1:n2 = 1:1
Pressure (pmax) = 70 [bar]

Benennung - Title
Axial Bohr und Fräskopf
Axial drilling and milling head

EWS
Tool Technologies
EWS Weigle GmbH & Co. KG
Maybachstr. 1
D-73066 Utingen
www.ews-tools.de

Technische Änderungen vorbehalten!
Subject to technical modifications!

IDENT: DEWS250873

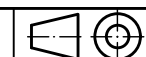

REV: -/A

Nr. - No.
40.55251809PFIKCIM

MNR.
230078

