

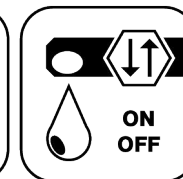

Butterfly Seal



Coolant Management



Tech Details

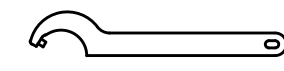
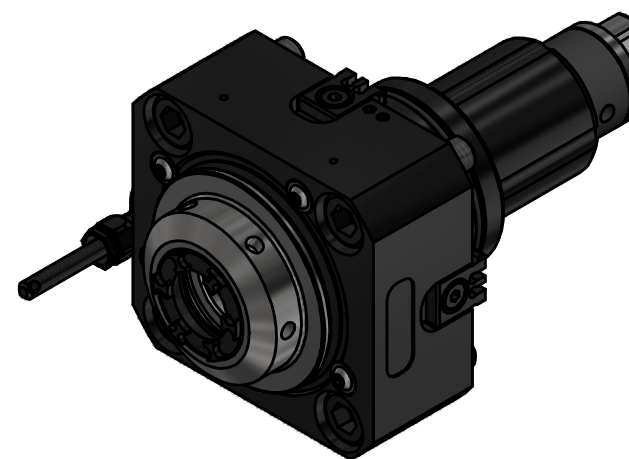
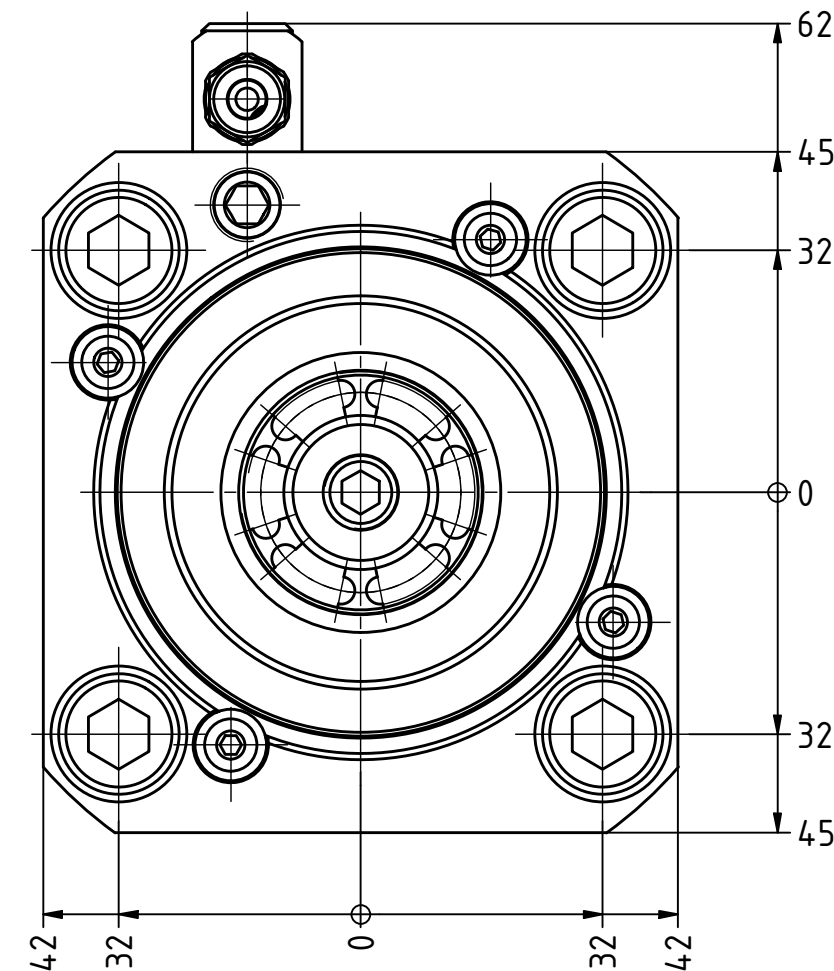
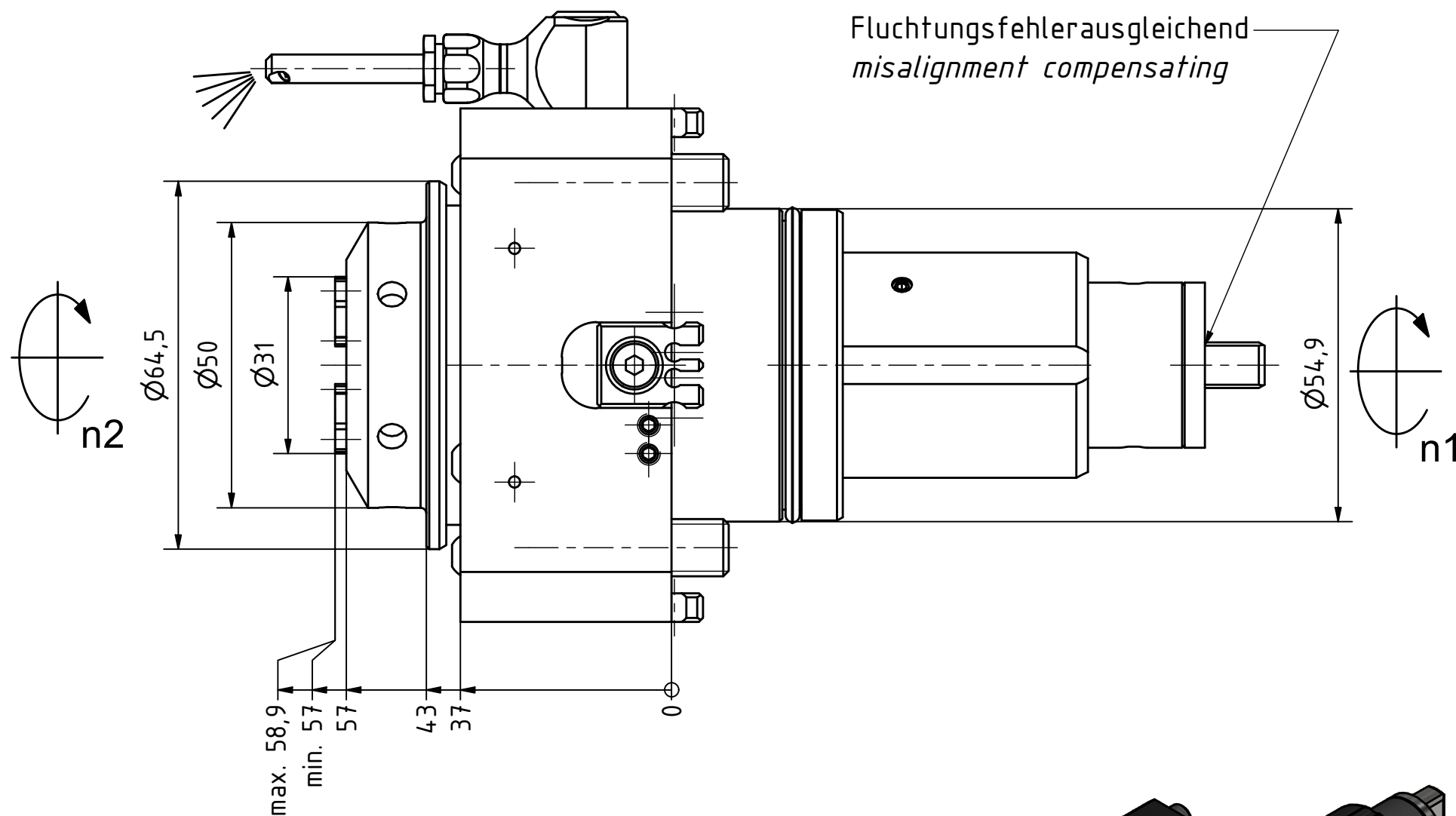

Hakenschlüssel mit Zapfen
Hook wrench with fixed pin
DIN1810 B 45x50

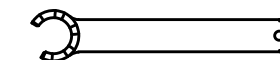

Spannzangenschlüssel für innenliegende Mutter
Clamping wrench for internal collet
225AX

Spannzange / collet ER25 DIN6499
Spannbereich / clamping range: 1,0 - 16,0

Gewindebohrzange / tapping collet
ET-1-25 M3-M12

Copyright **EWS Tool Technologies**
Weitergabe und Vervielfältigung dieser Unterlage, Verwertung und Mitteilung ihres Inhalts nicht gestattet, soweit nicht ausdrücklich zugestanden. Zuwiderhandlungen verpflichten zu Schadenersatz.

Bemerkung - Note

Technische Daten - technical data

Weight = 3.934 [kg]
Torque max. (M1/M2) = 63 / 63 [Nm]
Speed max. (n1/n2) = 6000 / 6000 [1/min]
Gear ratio (i)=n1:n2 = 1:1

Benennung - Title

Axial Bohr und Fräskopf
Axial drilling and milling head



Nr. - No.
40.55251809PFIM

Technische Änderungen vorbehalten!
Subject to technical modifications!

IDENT: DEWS250841



REV: -/A

MNR.

230077

