

Fluchtungsfehlerausgleichend
misalignment compensating

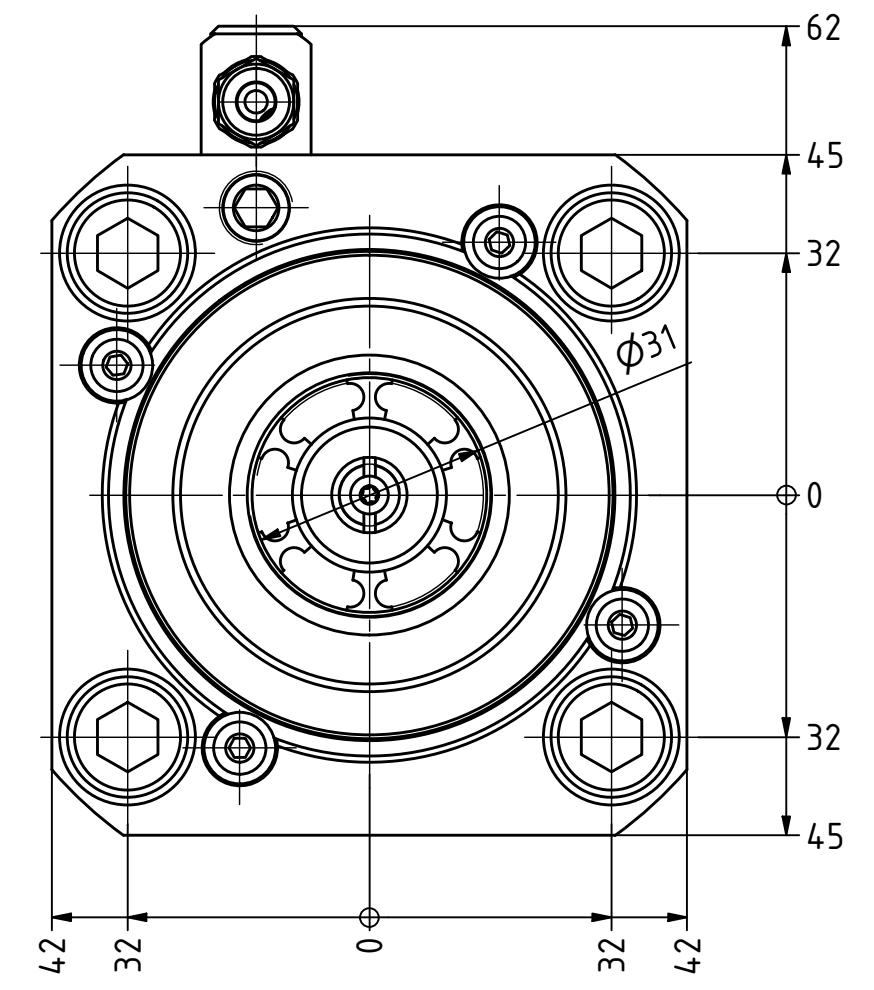

Spannzange / collet ER25 DIN6499
Spannbereich / clamping range: 1,0 - 16,0

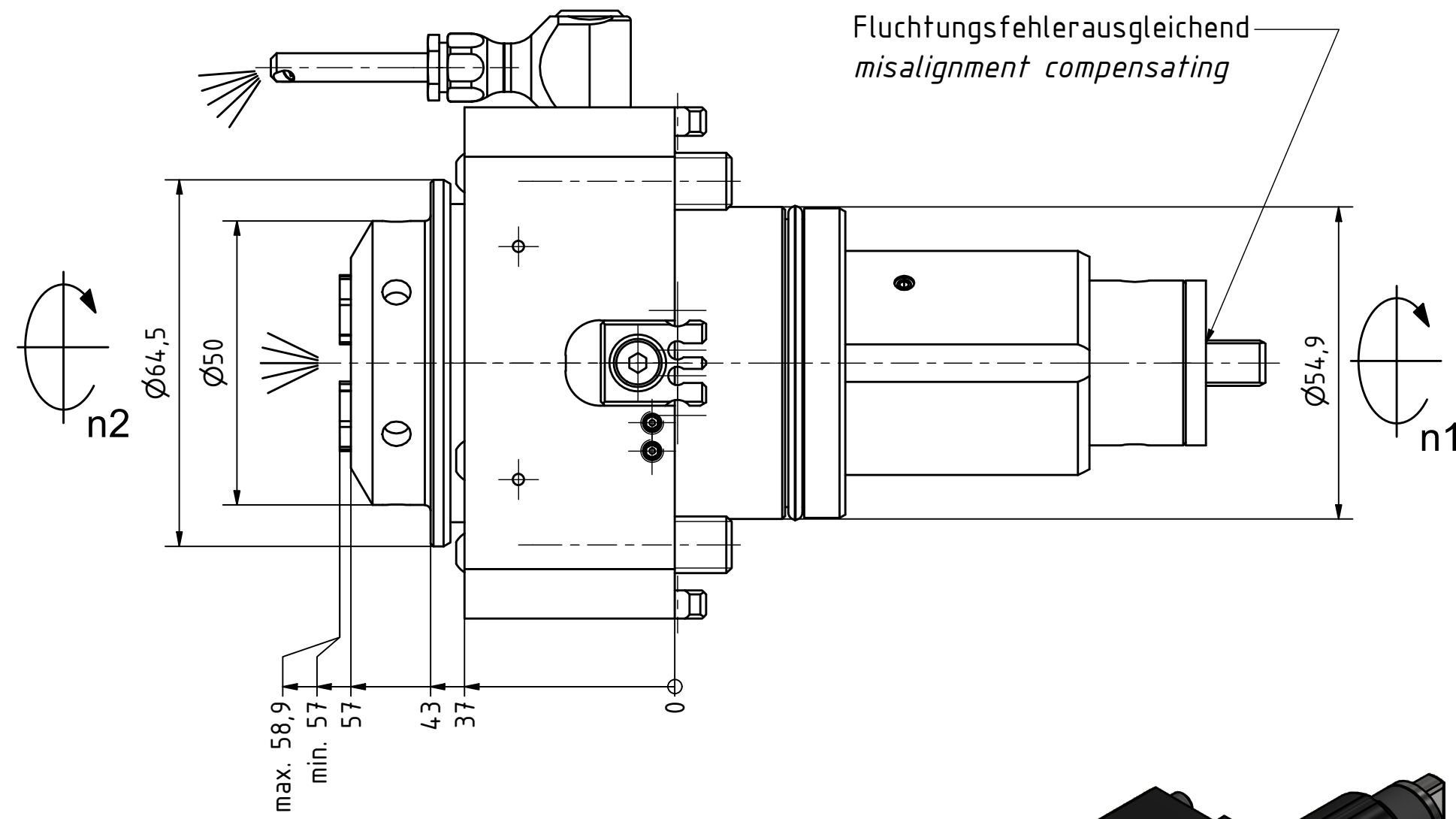
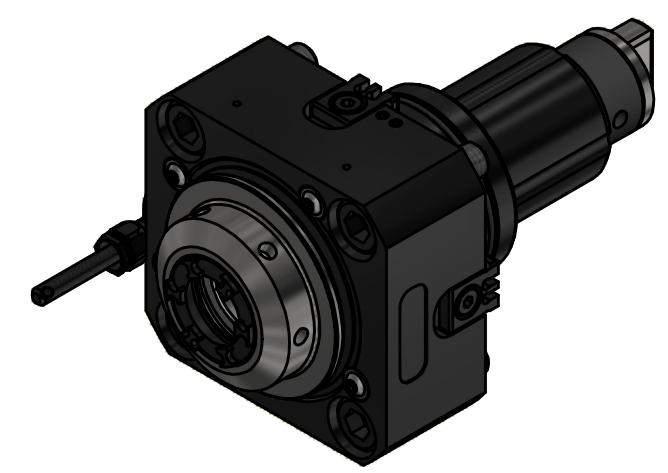
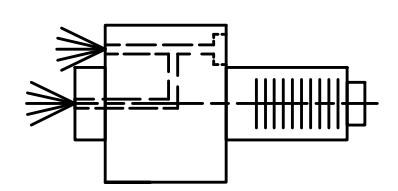

Hakenschlüssel mit Zapfen
Hook wrench with fixed pin
DIN1810 B 45x50

Spannzangenschlüssel für innenliegende Mutter
Clamping wrench for internal collet
225AX

Copyright **EWS Tool Technologies**
Weitergabe und Vervielfaeltigung dieser Unterlage, Verwertung und Mitteilung ihres Inhalts nicht gestattet, soweit nicht ausdrucklich zugestanden. Zuwiderhandlungen verpflichten zu Schadenersatz.

Bemerkung - Note
Für Trockenlauf geeignet!
Use without coolant fluid allowed!
mit Kegelrollenlager
with taper roller bearing(s)

Technische Daten - technical data

Weight	= 4.065 [kg]
Torque max. (M1/M2)	= 63 / 63 [Nm]
Speed max. (n1/n2)	= 5000 / 5000 [1/min]
Gear ratio (i)=n1:n2	= 1:1
Pressure (pmax)	= 70 [bar]

Benennung - Title
Axial Bohr und Fräskopf
Axial drilling and milling head

 <small>EWS Weigele GmbH & Co. KG Maybachstr. 1 D-73066 UHINGEN www.ews-tools.de</small>	Technische Aenderungen vorbehalten! Subject to technical modifications! IDENT: DEWS250935	 REV: -/A	
	Nr. - No. 40.5525KR1809PFIKCIM	MNR. 230084	