

Innen- und Aussenkuehlung / Inside and outside coolant supply  
Kuehlmittelfiltrierung<math>50\mu</math> / coolant filtration<math>50\mu</math>

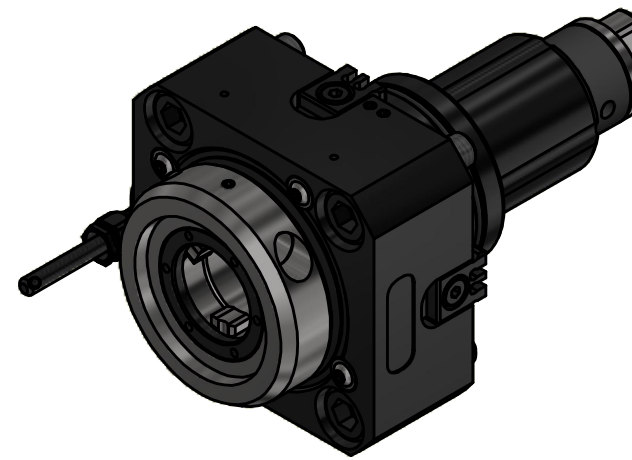

Copyright **EWS Tool Technologies**  
Weitergabe und Vervielfaeltigung dieser Unterlage,  
Verwertung und Mitteilung ihres Inhalts nicht  
gestattet, soweit nicht ausdrecklich zugestanden.  
Zuwiderhandlungen verpflichten zu Schadenersatz.

Bemerkung - Note  
Für Trockenlauf geeignet!  
Use without coolant fluid allowed!

Technische Daten - technical data	
Weight	= 4.073 [kg]
Torque max. (M1/M2)	= 63 / 63 [Nm]
Speed max. (n1/n2)	= 6000 / 6000 [1/min]
Gear ratio (i)=n1:n2	= 1:1
Pressure (pmax)	= 70 [bar]

Benennung - Title  
**Axial Bohr und Fräskopf**  
**Axial drilling and milling head**



Technische Aenderungen vorbehalten!  
Subject to technical modifications!

IDENT: DEWS250876

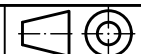

REV: -/A

Nr. - No.

**40.55VX31809PFIKC**

MNR.

**230082**

