

EWS.Varia Butterfly Seal Coolant Management Tech Details

Fluchtungsfehlerausgleichend
misalignment compensating

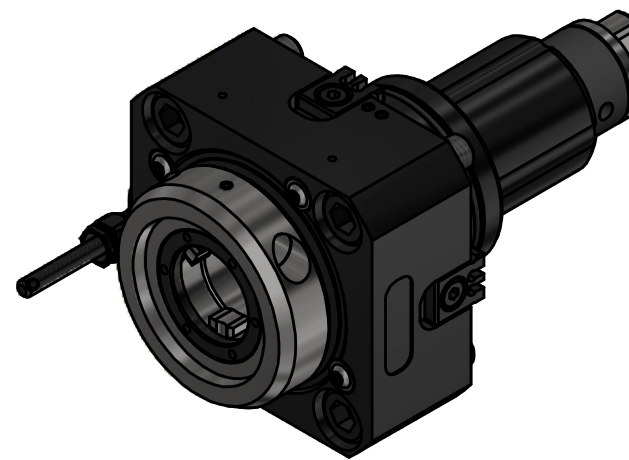
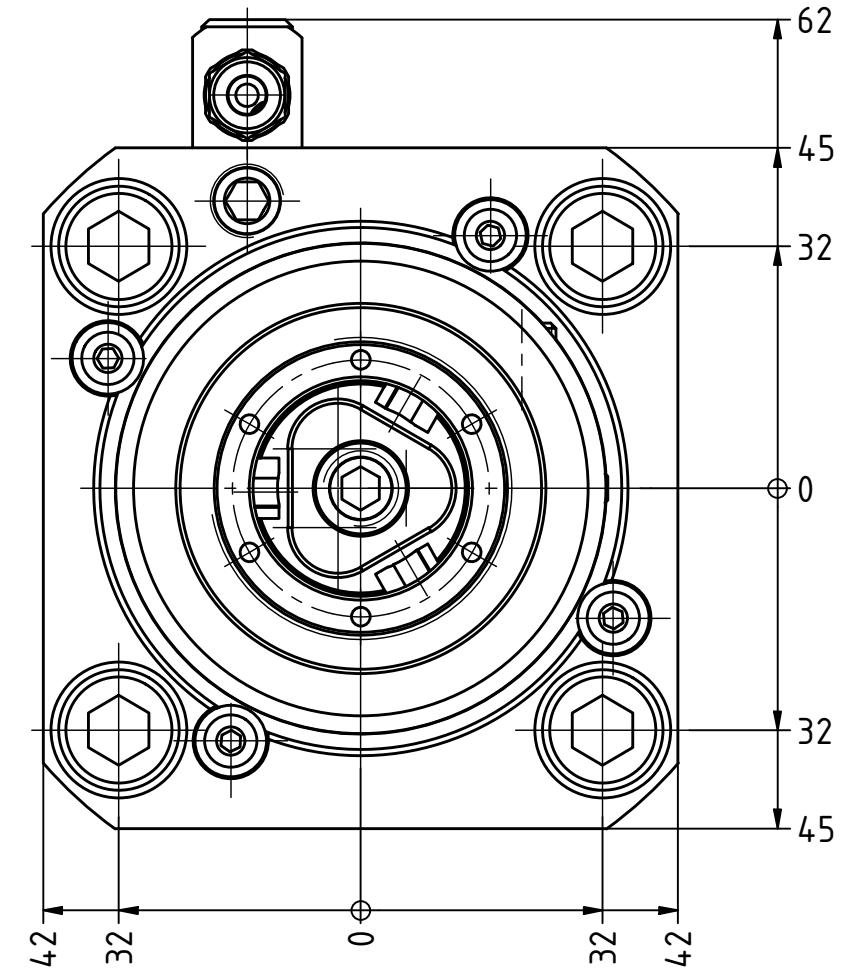
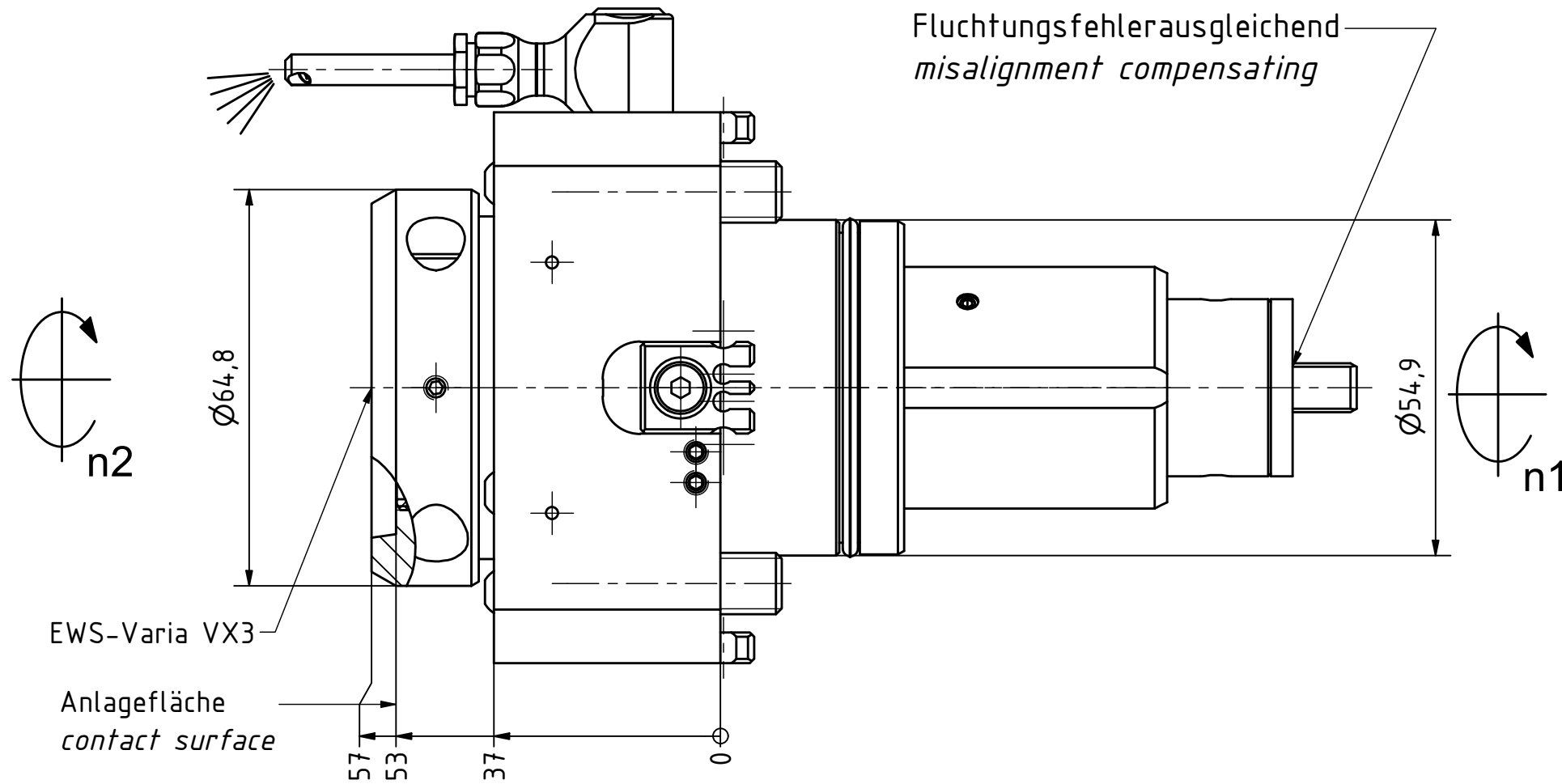

Copyright **EWS Tool Technologies**
Weitergabe und Vervielfältigung dieser Unterlage,
Verwertung und Mitteilung ihres Inhalts nicht
gestattet, soweit nicht ausdrücklich zugestanden.
Zu widerhandlungen verpflichten zu Schadenersatz.

Bemerkung - Note

Technische Daten - technical data

Benennung - Title

Weight = 3.979 [kg]
Torque max. (M1/M2) = 63 / 63 [Nm]
Speed max. (n1/n2) = 6000 / 6000 [1/min]
Gear ratio (i)=n1:n2 = 1:1

Axial Bohr und Fräskopf
Axial drilling and milling head



Nr. - No. **40.55VX31809PF**

Technische Änderungen vorbehalten!
Subject to technical modifications!

IDENT: DEWS250882

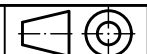

REV: -/A

MNR.

230081

