

Spannzange / collet ER32 DIN6499  
Spannbereich / clamping range: 2,0 - 20,0

Gewindebohrzange / tapping collet  
ET-1-32 M5-M12

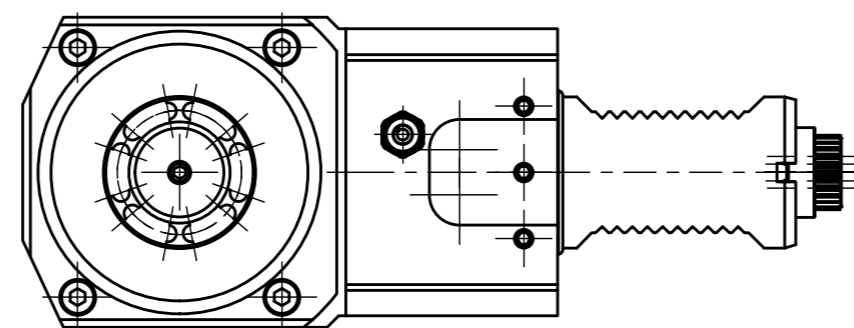

Doppelverzahnung Lizenz Traub  
double tooth system licence Traub

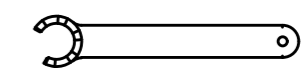
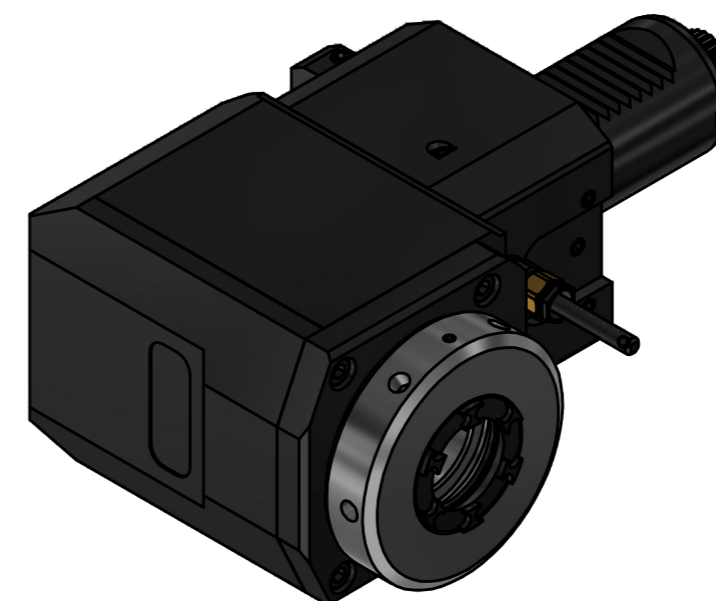

Spannzangenschlüssel für  
innenliegende Mutter  
Clamping wrench for  
internal collet

232AX

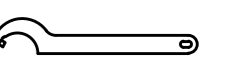

Hakenschlüssel  
mit Zapfen  
Hook wrench  
with fixed pin  
DIN1810 B 68x75

Copyright EWS Tool Technologies  
Weitergabe und Vervielfältigung dieser Unterlage,  
Verwertung und Mitteilung ihres Inhalts nicht  
gestattet, soweit nicht ausdrücklich zugestanden.  
Zuwerhandlungen verpflichten zu Schadenersatz.

|                  |  |   |  |
|------------------|--|---|--|
| Bemerkung - Note | Technische Daten - technical data<br>Weight = 7.688 [kg]<br>Torque max. (M1/M2) = 63 / 63 [Nm]<br>Speed max. (n1/n2) = 6000 / 6000 [1/min]<br>Gear ratio (i)=n1:n2 = 1:1 | Benennung - Title<br><b>Radial Bohr und Fräskopf</b><br><i>Radial drilling and milling head</i> | <div style="display: flex; justify-content: space-between;"> <div data-bbox="2226 1915 2463 2045"> <p><b>EWS</b> Weigle GmbH &amp; Co. KG<br/>Maybachstr. 1<br/>D-73066 Uhingen<br/>www.ews-tools.de</p> </div> <div data-bbox="2463 1915 2700 2045"> <p>Technische Änderungen vorbehalten!<br/>Subject to technical modifications!<br/>IDENT: DEWS251767</p> </div> <div data-bbox="2700 1915 2929 2045"> <p>Nr. - No. 60.4032CTXRLGLIM<br/>MNR. 230039</p> </div> </div> |
|------------------|--|---|--|