

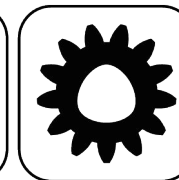

Butterfly Seal



Polygon Joint



Highspeed
1/min

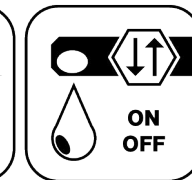

Coolant Management
ON
OFF



Tech Details

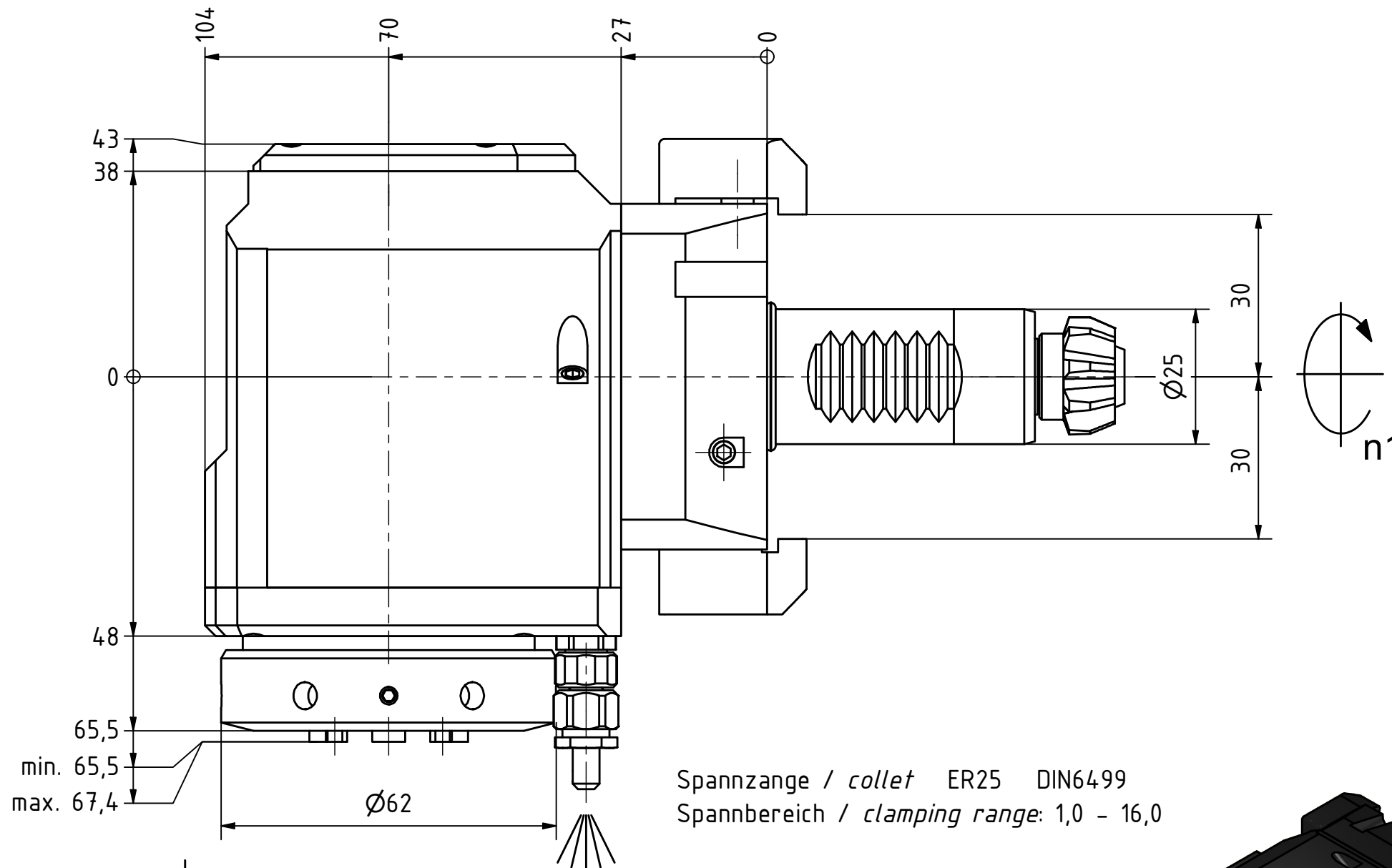

Spannzange / collet ER25 DIN6499
Spannbereich / clamping range: 1,0 - 16,0

Gewindebohrzange / tapping collet
ET-1-25 M3-M12

Doppelverzahnung Lizenz Traub
double tooth system licence Traub

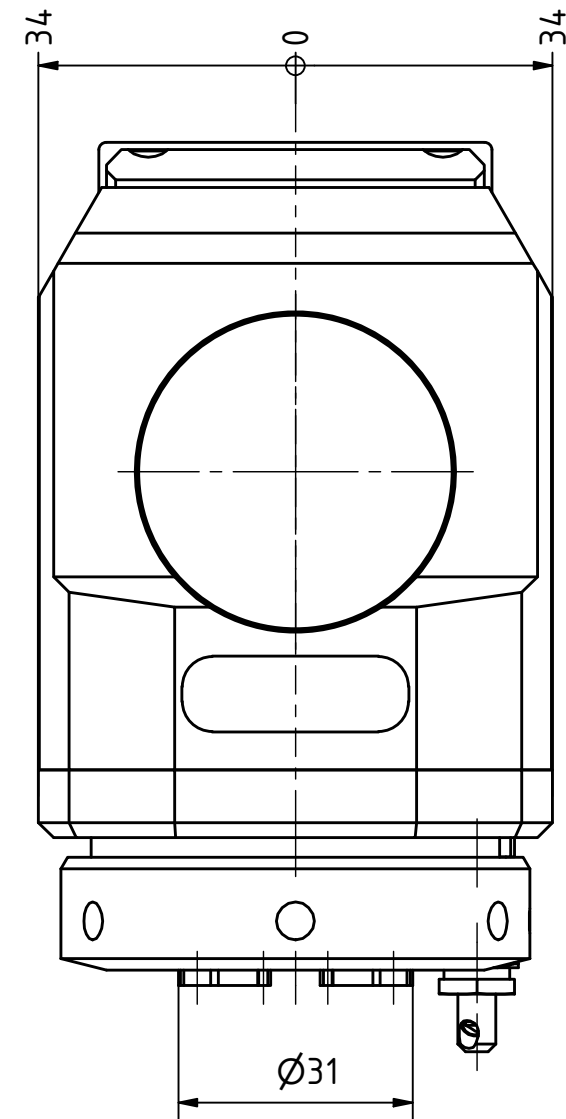

Hakenschlüssel
mit Zapfen
Hook wrench
with fixed pin
DIN1810 B 58x62

Spannzangenschlüssel für
innenliegende Mutter
Clamping wrench for
internal collet
225AX

Copyright **EWS Tool Technologies**
Weitergabe und Vervielfältigung dieser Unterlage,
Verwertung und Mitteilung ihres Inhalts nicht
gestattet, soweit nicht ausdrücklich zugestanden.
Zuwendungen verpflichten zu Schadenersatz.

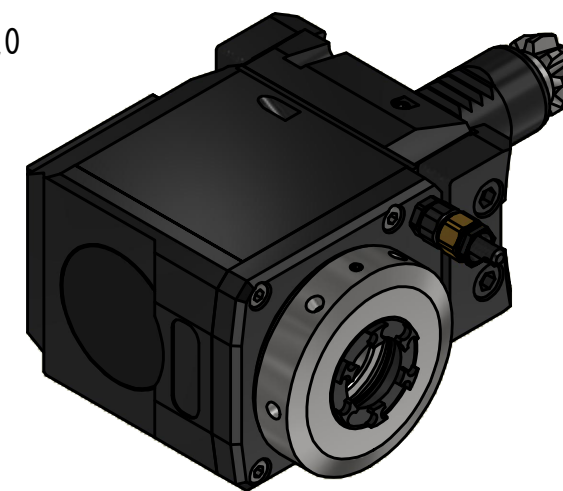

Bemerkung - Note

Technische Daten - technical data

Weight = 3.938 [kg]
Torque max. (M1/M2) = 24 / 12 [Nm]
Speed max. (n1/n2) = 6000 / 12000 [1/min]
Gear ratio (i)=n1:n2 = 1:2

Benennung - Title

Radial Bohr und Fräskopf
Radial drilling and milling head



Nr. - No.
60.2525ABCRL11M

Technische Änderungen vorbehalten!
Subject to technical modifications!

IDENT: DEWS251130

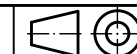

REV: -/A

MNR.

229883

