

Spannzange / collet ER25 DIN6499
Spannbereich / clamping range: 1,0 - 16,0

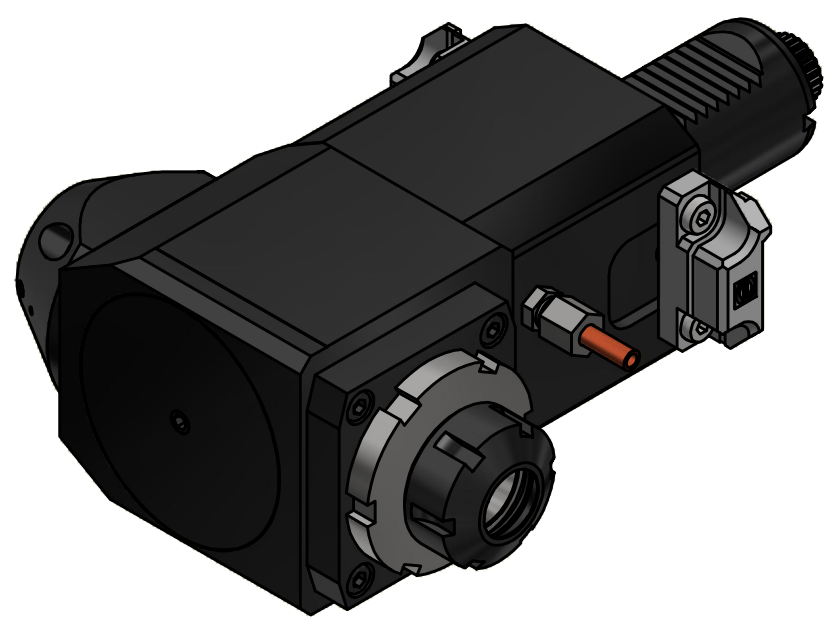

Hakenschlüssel mit Nase
Hook wrench with nose end
DIN1810 A 58x62

Spannzangenschlüssel
Clamping wrench
225

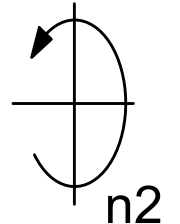
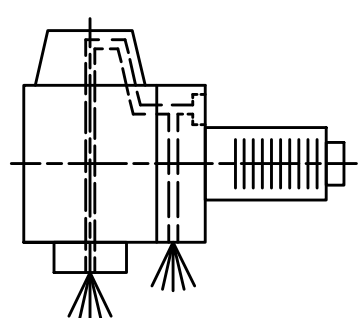

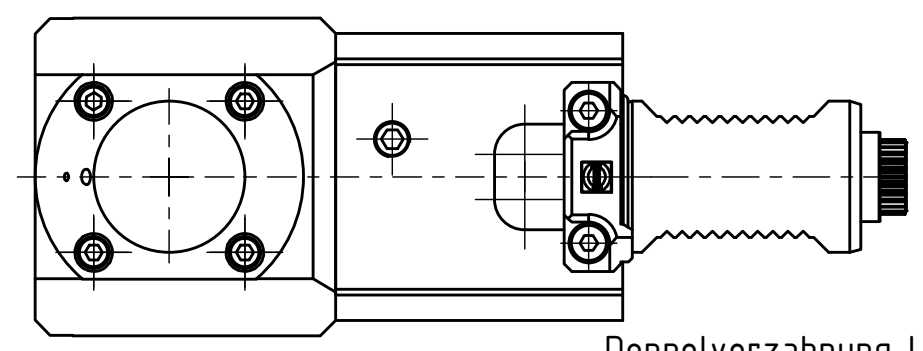

Innen- und Aussenkuehlung / Inside and outside coolant supply
Kein Trockenlauf / No dry run
Kuehlmittelfiltrierung=50µ / coolant filtration=50µ



Doppelverzahnung Lizenz Traub
double tooth system licence Traub

Bemerkung - Note Nicht ohne Kuehlmittel betreiben! Not for use without coolant-fluid!	Technische Daten - technical data
	Weight = 7.870 [kg]
	Torque max. (M1/M2) = 45 / 15 [Nm]
	Speed max. (n1/n2) = 5000 / 15000 [1/min]
	Pressure (pmax) = 70 [bar]

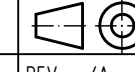
Benennung - Title
Radial Bohr und Fräskopf
Radial drilling and milling head

 <small>EWS Weigle GmbH & Co. KG Maybachstr. 1 D-73066 Uhlingen www.ews-tools.de</small>	<small>Technische Aenderungen vorbehalten! Subject to technical modifications!</small> IDENT: DEWS250793	 REV: -/A	
	Nr. - No. 60.4025LCTXRLIK113TFR	MNR. 229823	

Copyright **EWS Tool Technologies**
Weitergabe und Vervielfaeltigung dieser Unterlage,
Verwertung und Mitteilung ihres Inhalts nicht
gestattet, soweit nicht ausdrecklich zugestanden.
Zuwoerhandlungen verpflichten zu Schadenersatz.