

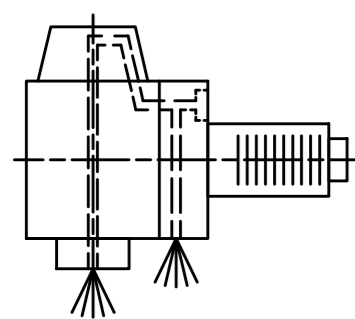

Polygon ISO 26623 PSC 40

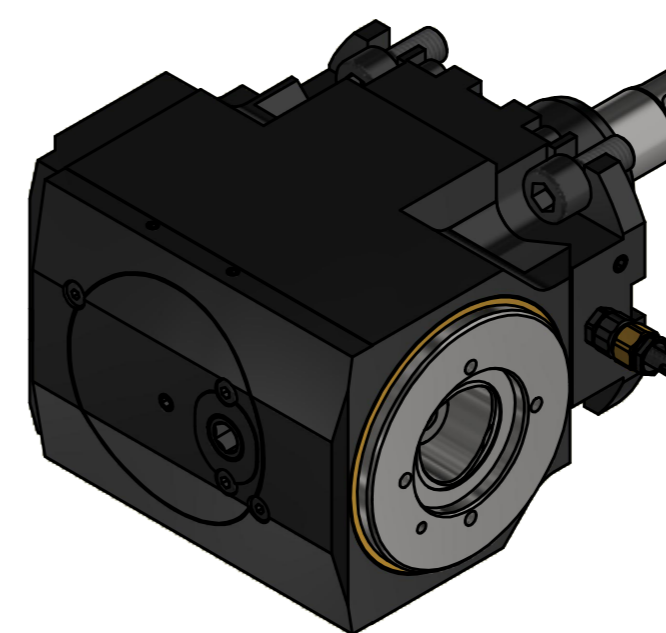

Innen- und Aussenkuehlung / Inside and outside coolant supply
Kuehlmittelfiltrierung=50µ / coolant filtration=50µ

Clamping torque
45 Nm

Copyright **EWS Tool Technologies**
Weitergabe und Vervielfaeltigung dieser Unterlage,
Verwertung und Mitteilung ihres Inhalts nicht
gestattet, soweit nicht ausdrecklich zugestanden.
Zuwoiderhandlungen verpflichten zu Schadensersatz.

<p>Bemerkung - Note Für Trockenlauf geeignet! Use without coolant fluid allowed!</p>	<p>Technische Daten - technical data Weight = 7.867 [kg] Torque max. (M1/M2) = 32 / 32 [Nm] Speed max. (n1/n2) = 6000 / 6000 [1/min] Gear ratio (i)=n1:n2 = 1:1 Pressure (pmax) = 70 [bar]</p>	<p>Benennung - Title Radial Bohr und Fräskopf Radial drilling and milling head</p>	 <p>EWS Weigle GmbH & Co. KG Maybachstr. 1 D-73066 Uhlingen www.ews-tool.de</p>	<p>Technische Aenderungen vorbehalten! Subject to technical modifications! IDENT: DEWS254993 REV: -/B MNR. 229706</p>	 <p>QR</p>
--	--	--	--	---	---