

Anlagefläche  
contact surface

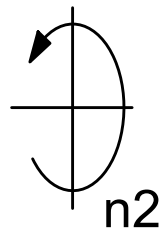

EWS-Varia VX3

Ø64,8

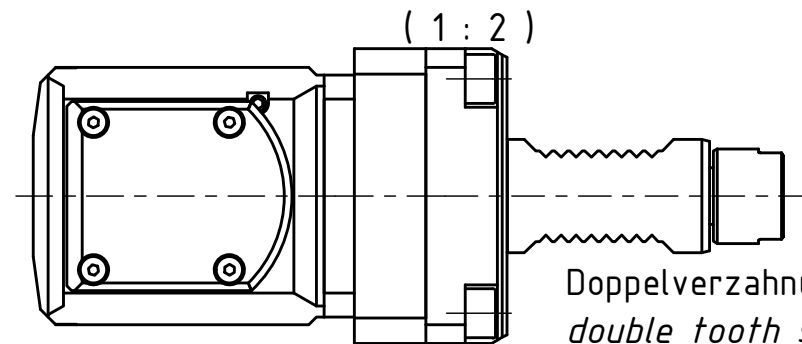

Doppelverzahnung Lizenz Traub  
double tooth system licence Traub

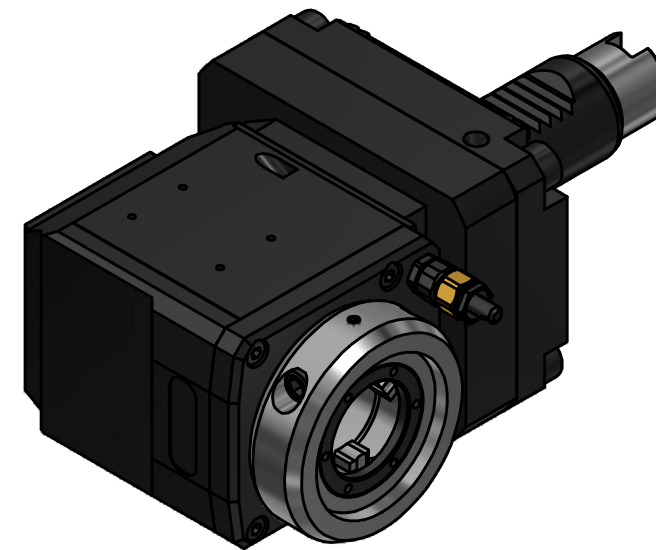

Copyright **EWS Tool Technologies**  
Weitergabe und Vervielfaeltigung dieser Unterlage,  
Verwertung und Mitteilung ihres Inhalts nicht  
gestattet, soweit nicht ausdrecklich zugestanden.  
Zuwiderhandlungen verpflichten zu Schadenersatz.

Bemerkung - Note

Technische Daten - technical data

Weight = 5.595 [kg]  
Torque max. (M1/M2) = 20 / 40 [Nm]  
Speed max. (n1/n2) = 8000 / 4000 [1/min]  
Gear ratio (i)=n1:n2 = 2:1

Benennung - Title

**Radial Bohr und Fräskopf**  
**Radial drilling and milling head**

**EWS**  
Tool Technologies

EWS Weigele GmbH & Co. KG  
Maybachstr. 1  
D-73066 UHINGEN  
www.ews-tools.de

Technische Aenderungen vorbehalten!  
Subject to technical modifications!

IDENT: DEWS250379



REV: -/A

Nr. - No.

60.30VX3G300RLI2W#01

MNR.

229727

**QR**