

Spannzange / collet ER25 DIN6499  
 Spannbereich / clamping range: 1,0 - 16,0

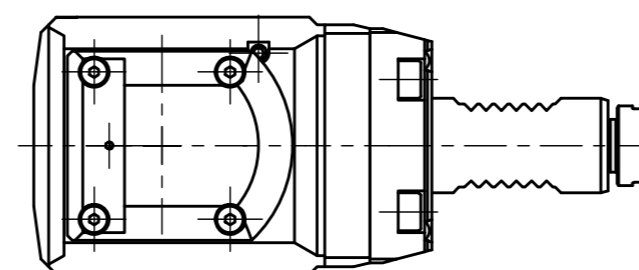

Doppelverzahnung Lizenz Traub  
 double tooth system licence Traub

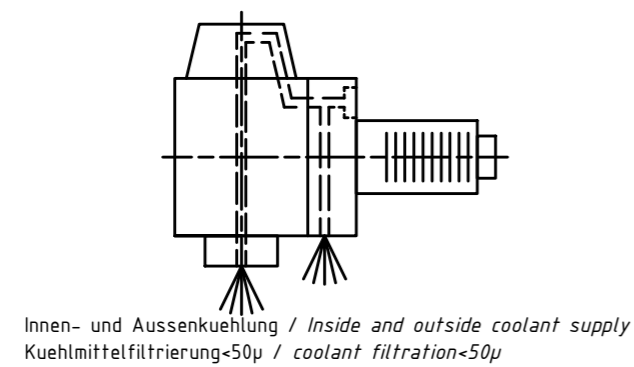
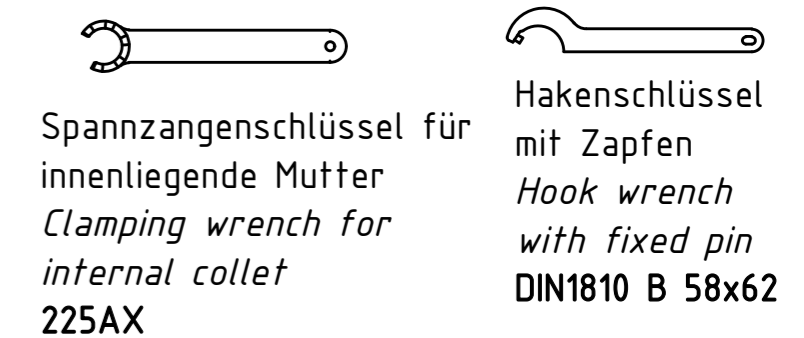
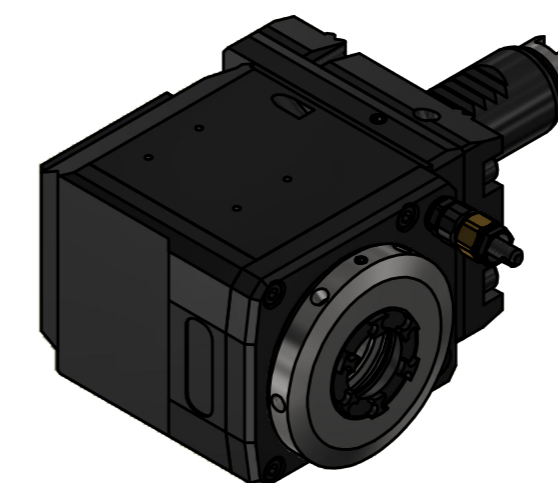

Copyright EWS Tool Technologies  
 Weitergabe und Vervielfaeltigung dieser Unterlage,  
 Verwertung und Mitteilung ihres Inhalts nicht  
 gestattet, soweit nicht ausdrecklich zugestanden.  
 Zuwiderhandlungen verpflichten zu Schadenersatz.

<p>Bemerkung - Note          Für Trockenlauf geeignet!          Use without coolant fluid allowed!</p>	<p>Technische Daten - technical data          Weight = 4,068 [kg]          Torque max. (M1/M2) = 25 / 25 [Nm]          Speed max. (n1/n2) = 8000 / 8000 [1/min]          Gear ratio (i)=n1:n2 = 1:1          Pressure (pmax) = 70 [bar]</p>	<p>Benennung - Title  <b>Radial Bohr und Fräskopf</b>  <b>Radial drilling and milling head</b></p>	<p><b>EWS</b> Tool Technologies  <small>EWS Weigle GmbH &amp; Co. KG          Maybachstr. 1          D-73066 Uhlingen          www.ews-tool.de</small></p> <p>Technische Aenderungen vorbehalten!          Subject to technical modifications!          IDENT: DEWS260846</p> <p>Nr. - No. <b>60.2525G200RLIKDWIM-CB</b></p> <p>REV: -/A          MNR. <b>229666</b></p> <p><b>QR</b></p>
--	---	--	---