

Doppelverzahnung Lizenz Traub
double tooth system licence Traub

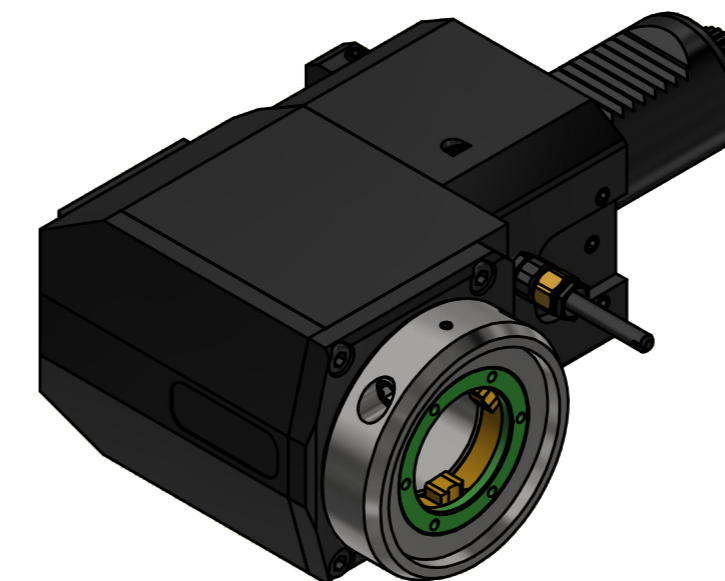

Copyright **EWS Tool Technologies**
Weitergabe und Vervielfältigung dieser Unterlage,
Verwertung und Mitteilung ihres Inhalts nicht
gestattet, soweit nicht ausdrücklich zugestanden.
Zuwerhandlungen verpflichten zu Schadenersatz.

Bemerkung - Note	Technische Daten - technical data Weight = 6.755 [kg] Torque max. (M1/M2) = 50 / 25 [Nm] Speed max. (n1/n2) = 6000 / 12000 [1/min] Gear ratio (i)=n1:n2 = 1:2	Benennung - Title Radial Bohr und Fräskopf Radial drilling and milling head	 EWS Weigle GmbH & Co. KG Maybachstr. 1 D-73066 Uhingen www.ews-tools.de	Technische Änderungen vorbehalten! Subject to technical modifications! IDENT: DEWS250062 Nr. - No. 60.40VX4CTXRLI1#01	REV: -/A MNR. 229653	
------------------	---	---	--	--	-----------------------------------	--