

Butterfly Seal Polygon Joint Coolant Management Tech Details

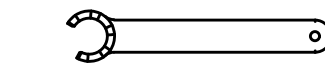

Spannzangenschlüssel für innenliegende Mutter  
Clamping wrench for internal collet  
225AX

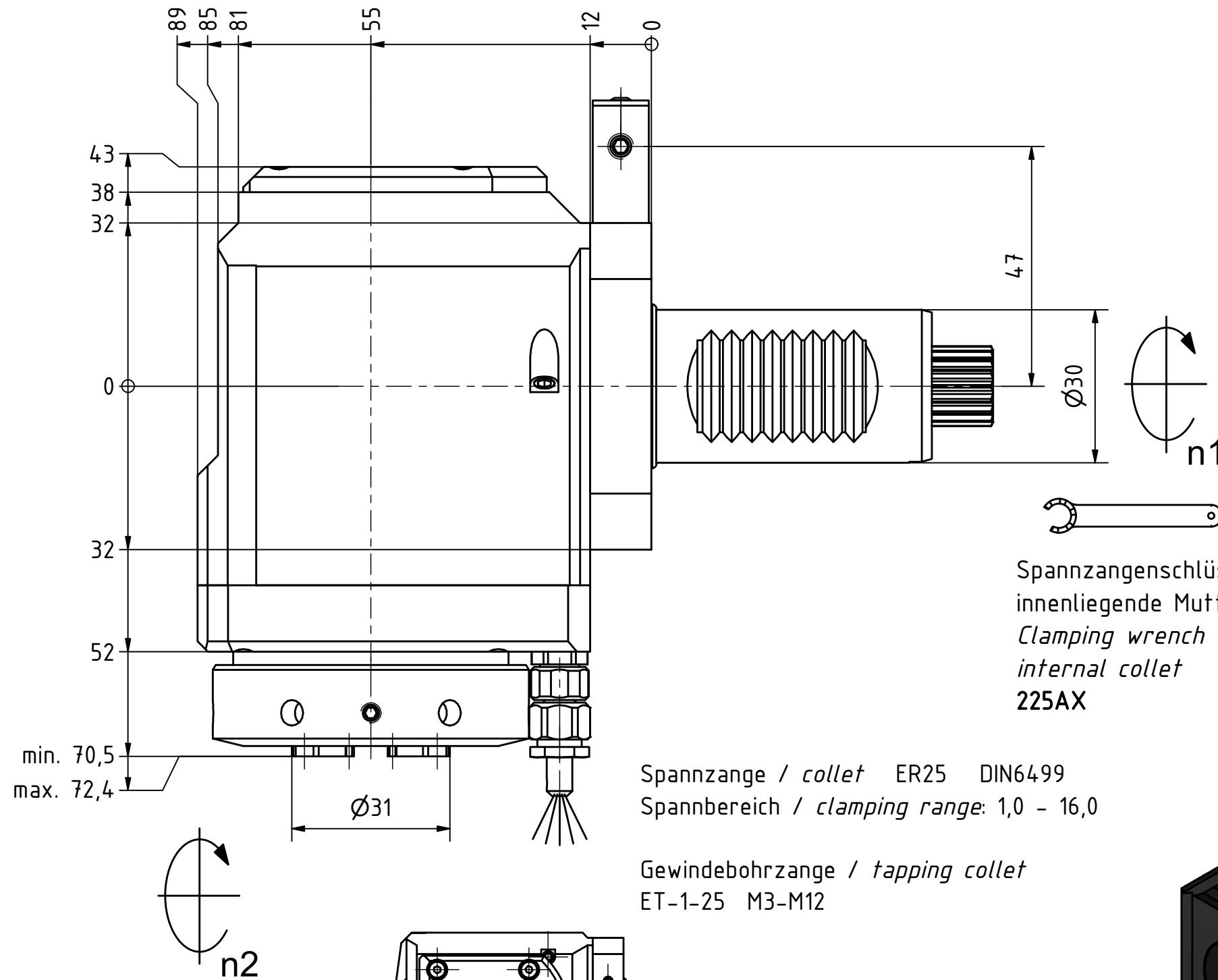
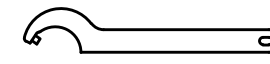

Hakenschlüssel mit Zapfen  
Hook wrench with fixed pin  
DIN1810 B 58x62

Spannzange / collet ER25 DIN6499  
Spannbereich / clamping range: 1,0 - 16,0

Gewindebohrzange / tapping collet  
ET-1-25 M3-M12

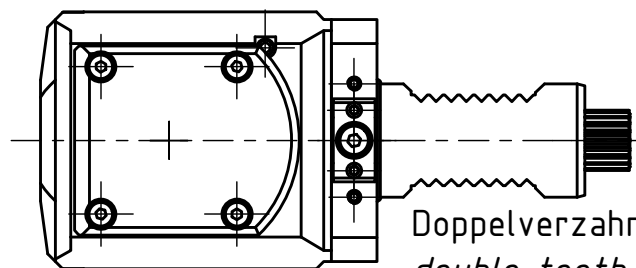

Doppelverzahnung Lizenz Traub  
double tooth system licence Traub

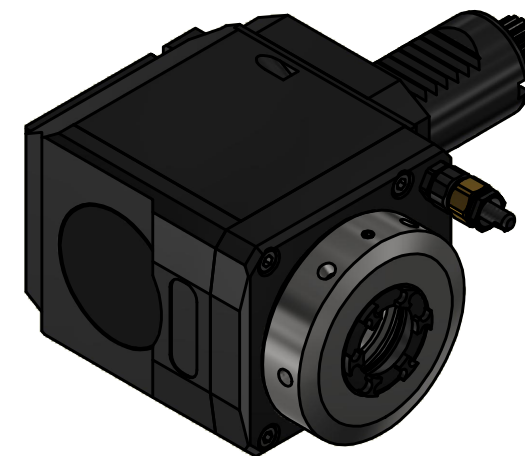
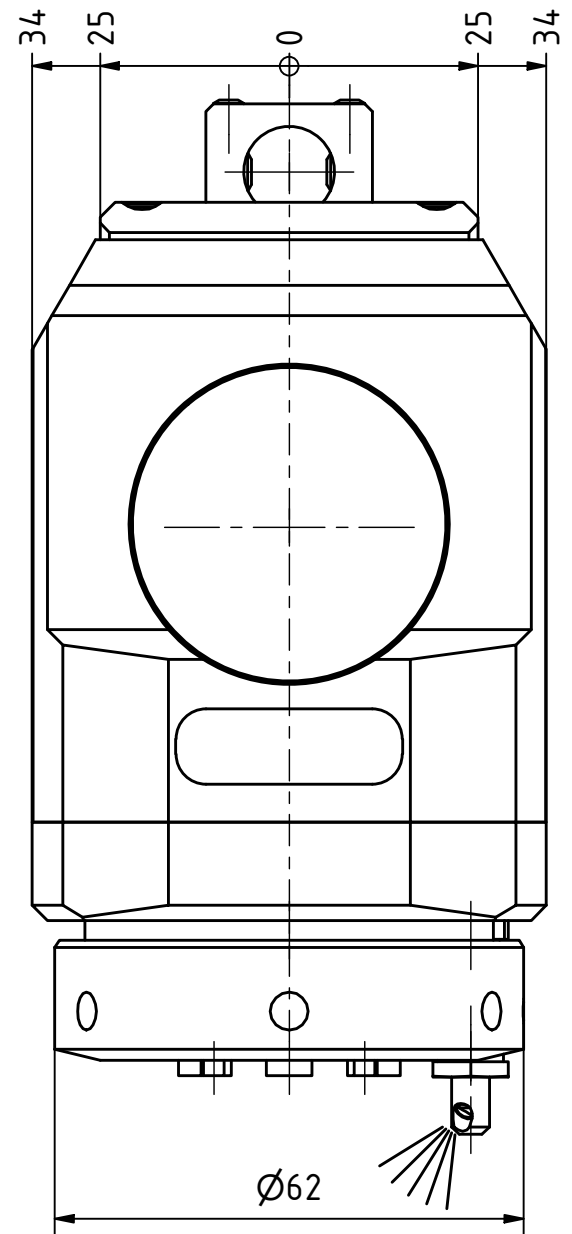

Copyright **EWS Tool Technologies**  
Weitergabe und Vervielfältigung dieser Unterlage,  
Verwertung und Mitteilung ihres Inhalts nicht  
gestattet, soweit nicht ausdrücklich zugestanden.  
Zuwerhandlungen verpflichten zu Schadenersatz.

Bemerkung - Note

Technische Daten - technical data

Weight = 3.311 [kg]  
Torque max. (M1/M2) = 32 / 32 [Nm]  
Speed max. (n1/n2) = 8000 / 8000 [1/min]  
Gear ratio (i)=n1:n2 = 1:1

Benennung - Title

**Radial Bohr und Fräskopf**  
**Radial drilling and milling head**

**EWS** Tool Technologies  
EWS Weigle GmbH & Co. KG  
Maybachstr. 1  
D-73066 Uhingen  
www.ews-tools.de

Technische Änderungen vorbehalten!  
Subject to technical modifications!

IDENT: DEWS250122

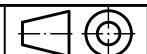

REV: -/A

Nr. - No.

60.3025MFSRLGLIM

MNR.

229644

**QR**