

Anlagefläche
contact surface

EWS-Varia VX3

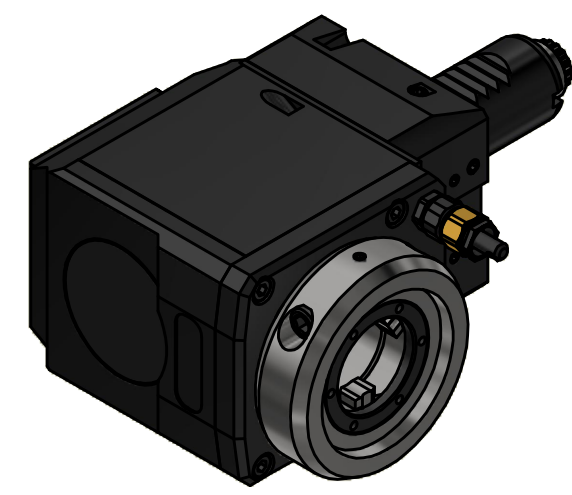

Innen- und Aussenkuehlung / Inside and outside coolant supply
Kuehlmittelfiltrierung-50µ / coolant filtration<50µ

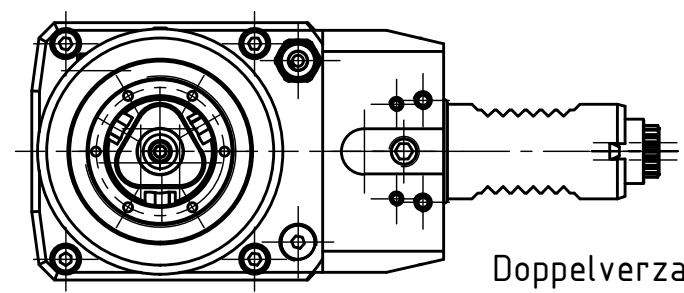

Doppelverzahnung Lizenz Traub
double tooth system licence Traub

Copyright **EWS Tool Technologies**
Weitergabe und Vervielfaeltigung dieser Unterlage,
Verwertung und Mitteilung ihres Inhalts nicht
gestattet, soweit nicht ausdrucklich zugestanden.
Zuwiderhandlungen verpflichten zu Schadenersatz.

<p>Bemerkung - Note</p> <p>Für Trockenlauf geeignet! Use without coolant fluid allowed!</p>	<p>Technische Daten - technical data</p> <p>Weight = 3.997 [kg] Torque max. (M1/M2) = 24 / 12 [Nm] Speed max. (n1/n2) = 6000 / 12000 [1/min] Gear ratio (i)=n1:n2 = 1:2 Pressure (pmax) = 70 [bar]</p>	<p>Benennung - Title</p> <p>EWS Tool Technologies EWS Weigele GmbH & Co. KG Maybachstr. 1 D-73066 Uthingen www.ews-tools.de</p> <p>Nr. - No. 60.25VX3L5480RLIKDI1</p>	<p>Technische Aenderungen vorbehalten! Subject to technical modifications!</p> <p>IDENT: DEWS250093</p> <p>REV: -/A</p> <p>MNR. 229638</p>	
---	--	---	---	--