

Hydrodehnfutter / hydraulic chuck NBC-20/25-46

Hülsen / collets 28.20xxHYDSP

XX (Ø) 3 4 5 6 7 8 9 10 12 14 16
 1/8 3/16 1/4 5/16 3/8 7/16 1/2 9/16 5/8



Ceramic Seal

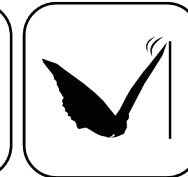

Butterfly Seal

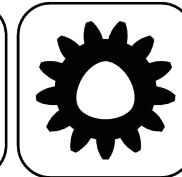

Polygon Joint



Coolant Management



Tech Details

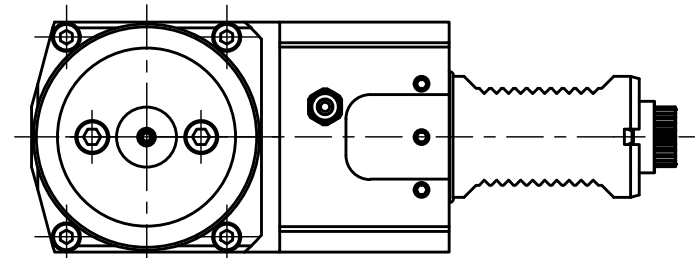
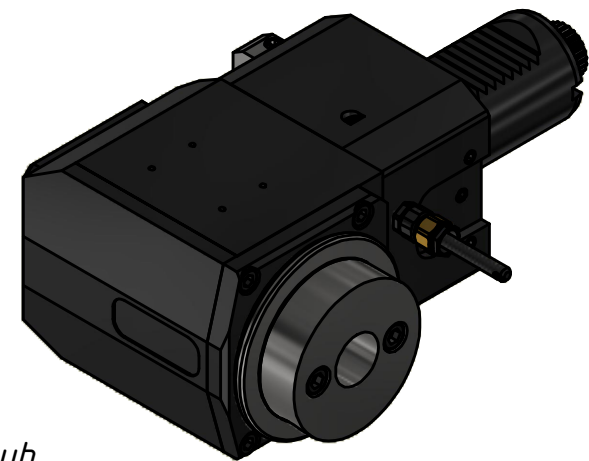
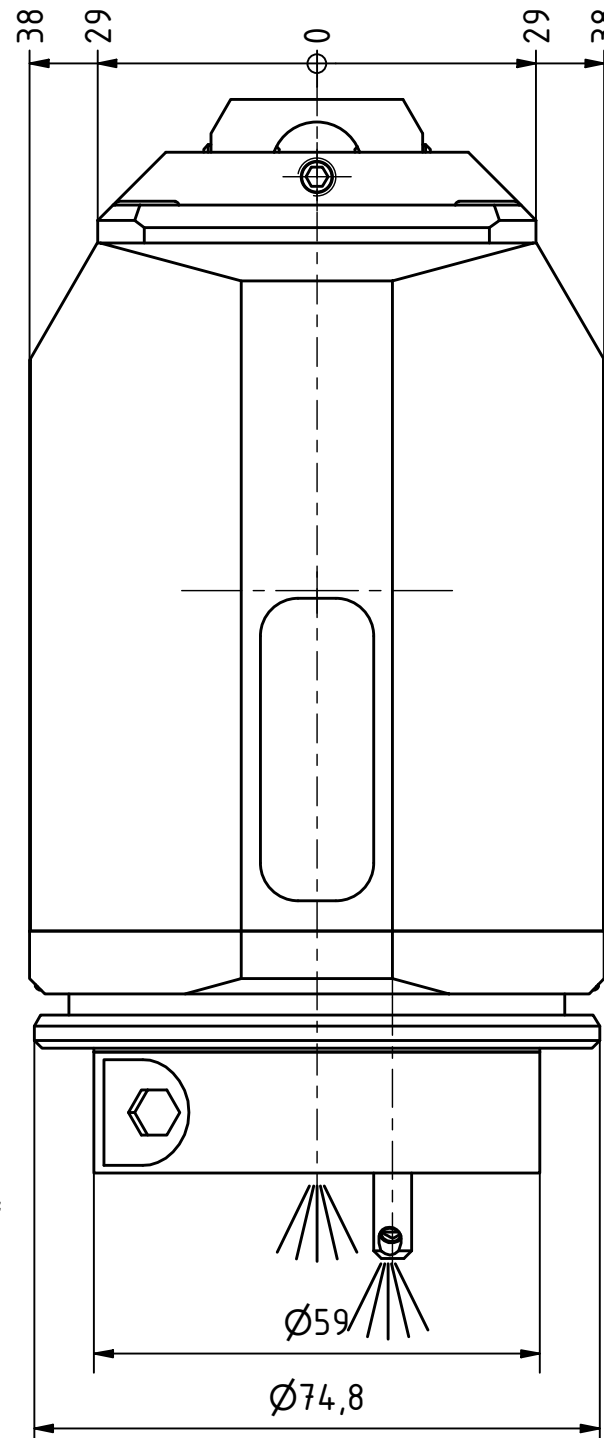
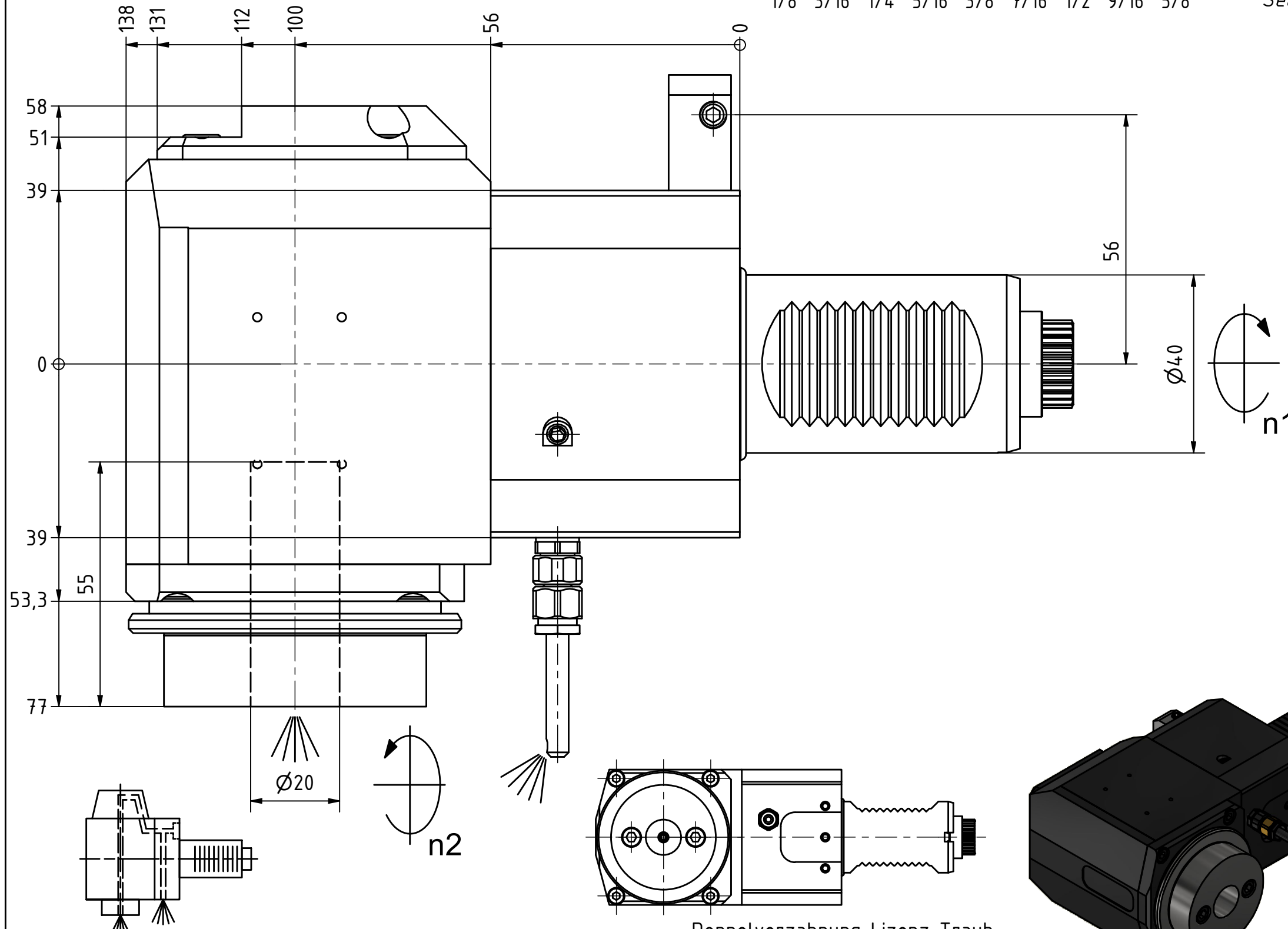

Doppelverzahnung Lizenz Traub
 double tooth system licence Traub

Innen- und Aussenkühlung / Inside and outside coolant supply
 Kühlmittelfiltrierung-50 μ / coolant filtration-50 μ

Bemerkung - Note
 Für Trockenlauf geeignet!
 Use without coolant fluid allowed!

Technische Daten - technical data
 Weight = 6.868 [kg]
 Torque max. (M1/M2) = 63 / 63 [Nm]
 Speed max. (n1/n2) = 6000 / 6000 [1/min]
 Gear ratio (i)=n1:n2 = 1:1
 Pressure (pmax) = 70 [bar]

Benennung - Title
Radial Bohr und Fräskopf
Radial drilling and milling head



Nr. - No.
60.4020HYDCTXRLIKD

Technische Änderungen vorbehalten!
 Subject to technical modifications!

IDENT: DEWS253074



REV: -/A

MNR.

229632



Copyright **EWS Tool Technologies**
 Weitergabe und Vervielfältigung dieser Unterlage,
 Verwertung und Mitteilung ihres Inhalts nicht
 gestattet, soweit nicht ausdrücklich zugestanden.
 Zuwiderhandlungen verpflichten zu Schadenersatz.